

Micro Switch

V Series



Part Number Description

V 15F - C

① Description	No mark : Standard	V : Special (Only 01)		
② Head Type	01 : Push Plunger	06 : Lever	070 : Round Lever	060 : Long Lever
	07 : Roller Long Lever	08 : Short Lever	09 : Roller Short Lever	

VAP - 1 2

① Button Size	10 : Ø10	13 : Ø13	18 : Ø18	
② Button Color	R : Red	G : Green	Y : Yellow	K : Black

General Specification

Contact Form	1C		
Contact Material	Ag alloy		
Contact & Contact Distance	0.5mm		
Insulation Resistance	100MΩ min.(at 500VDC)		
Contact Resistance	Max. 50mΩ		
Maximum Inrush Current	Norminal Open (N/O) 15A	Norminal Close (N/C) 30A	





Contact Ratings	Voltage	Non-Inductive				Inductive			
		Resistance Load		Lamp Load		Inductive Load		Motor Load	
		Norminal Open (N/O)	Norminal Close (N/C)	Norminal Open (N/O)	Norminal Close (N/C)	Norminal Open (N/O)	Norminal Close (N/C)	Norminal Open (N/O)	Norminal Close (N/C)
	125VAC	15A	15A	1.5A	3A	10A	10A	2.5A	4A
	250VAC	10A	15A	1.0A	2A	6A	10A	1A	3A
	8VDC	10A	15A	1.5A	4A	8A	10A	2.5A	6A
	14VDC	5A	15A	1.5A	4A	4A	10A	2.5A	6A
	30VDC	2A	10A	1.0A	4A	1.5A	6A	1.5A	4A
	125VDC	0.5A	0.6A	0.1A	0.1A	0.05A	0.6A	0.05A	0.01A
	250VDC	0.25A	0.3A	0.05A	0.05A	0.03A	0.3A	0.04A	0.05A

The aforementioned values are steady-state current values.
 The inductive load has a power factor of 0.4 or more (AC), and a time constant of 7 m/s or less (DC).
 The inrush current is ten times larger than steady-state current in the lamp load, and six times, in the motor load.

Operating Speed	0.1 mm/sec ~ 0.5m/sec	
Dielectric Strength	1,500VAC 1 Minute	
Life Cycle	Electrical	Min. 100,000
	Mechanical	Min. 1,000,000
Vibration Resistance	10 ~ 55Hz(durable amplitude 1.5mm)	
Shock Resistance	30G	
Ambient Temperature	-25°C ~ +80°C (with no icing)Z	
Ambient Humidity	35% ~ 80% RH	

☞ The material and the specification of the product can be changed without notice for better quality.



Product Selection

	Color	Part Number	Contact Form	Contact & Contact Distance	PT	MD	OT	OP
	Black	V15F-01C	1C	0.5 mm	1.7mm	0.4mm	0.8mm	14.7 ±0.6 mm
	Black	V15F-06C	1C	0.5 mm	32mm	12mm	12mm	15.3 ±1.2 mm
	Black	V15F-070C	1C	0.5 mm	32mm	12mm	12mm	15.5 ±1.2 mm
	Black	V15F-060C	1C	0.5 mm	75mm	22mm	22mm	15.3 ±2.6 mm
	Black	V15F-07C	1C	0.5 mm	32mm	12mm	12mm	20.7 ±1.2 mm
	Black	V15F-08C	1C	0.5 mm	1.6mm	0.5mm	0.8mm	15.3 ±0.8 mm
	Black	V15F-09C	1C	0.5 mm	1.6mm	0.5mm	0.8mm	20.7 ±0.8 mm
	Black	V15F-01C	1C	0.5 mm	1.6mm	0.4mm	0.8mm	14.7 ±0.6 mm

Micro Switch

V Series

Product Selection

	Button Color	Part Number	Contact Form	Contact & Contact Distance	PT	MD	OT	OP
	Red	VAP - 10R	1C	0.5 mm	1.6mm	0.4mm	0.8mm	14.7 ±0.6 mm
	Green	VAP - 10G						
	Red	VAP - 13R	1C	0.5 mm	1.6mm	0.4mm	0.8mm	14.7 ±0.6 mm
	Green	VAP - 13G						
	Yellow	VAP - 13Y						
	Blue	VAP - 13B						
	Black	VAP - 13K						
	Red	VAP - 18R	1C	0.5mm	1.6mm	0.4mm	0.8mm	14.7 ±0.6 mm
	Green	VAP - 18G						
	Yellow	VAP - 18Y						
	Blue	VAP - 18B						
	Black	VAP - 18K						

Dimension

unit : mm

V15F - 01C

V15F - 06C

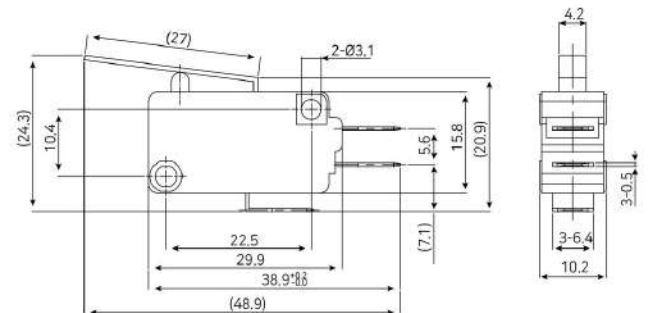
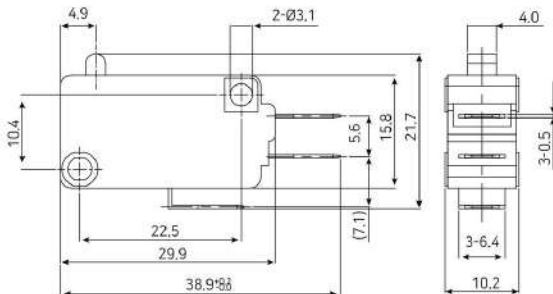

Dimension

unit : mm

V15F-07C

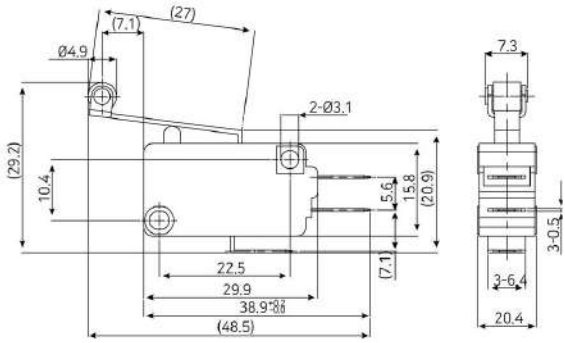

V15F-08C

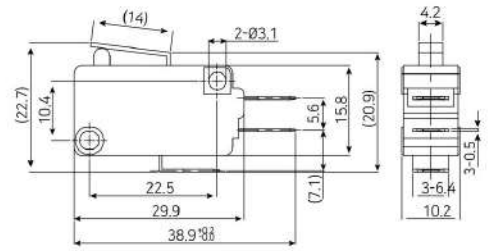

V15F-09C

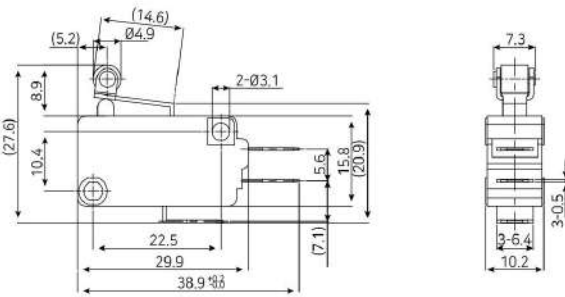

VV15F-01C

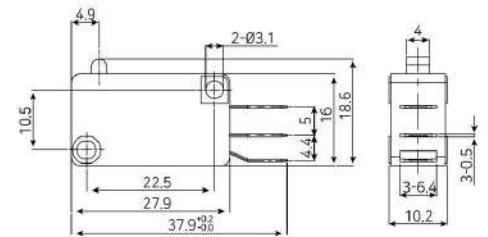

VAP-10

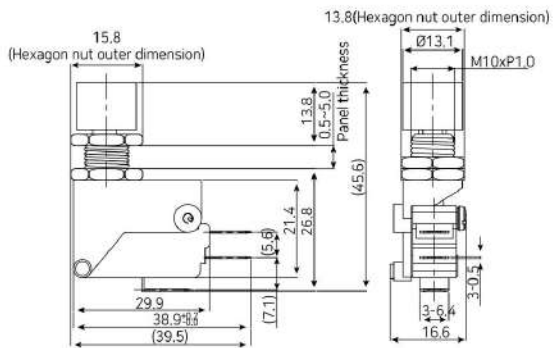

VAP-13

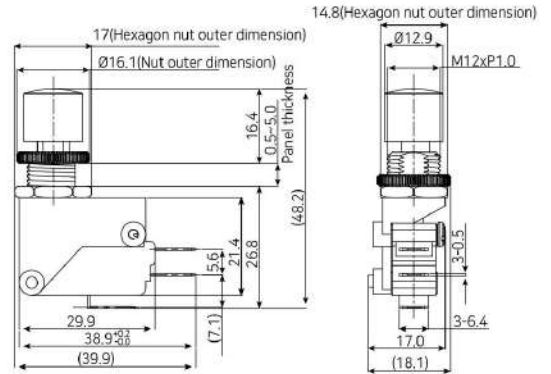

VAP-18

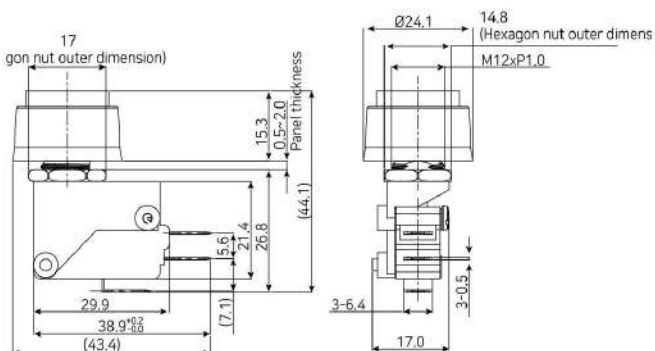

Micro Switch

V Series

Diagram

V15F - 01C

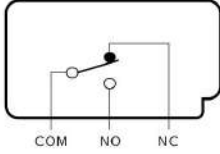

COM : Common terminal
NO : Always open terminal
NC : Always closed terminal

Glossary

Operating characteristics	Category	Abbr.	Term	Unit	Definition
	Force	Force required for operation	OF	g, kg g-mm	Force on the actuator required for the motion from the free position to the operating position
		Restoring force	RF	g, kg g-mm	Force on the actuator required for the motion from the operating limit position to the restoring position
		Force required for entire motion	TF	g, kg g-mm	Force on the actuator required for the motion from the operating position to the operating limit position
	Motion	Motion to the operating position	PT	mm, deg	Distance or angle from the free position of the actuator to the operating position
		Motion after operation	OT	mm, deg	Distance or angle from the operating position of the actuator to the operating limit position
		Hysteresis distance	MD	mm, deg	Distance or angle from the operating position of the actuator to the restoring position
		Total motion	TT	mm, deg	Distance or angle from the free position of the actuator to the operating limit position
	Position	Free position	FP	mm, deg	The position of the operating part when no force is applied from outside
		Operating position	OP	mm, deg	The position of the actuator when the external force is applied to the actuator and the moving contact reverses from the free position
		Restoring position	RP	mm, deg	The position of the actuator when the external force to the actuator is reduced and the moving contact reverses from the operating position to the free position
		Operating limit position	TTP	mm, deg	The position of the actuator when the actuator reaches the actuator stop position

Terminal

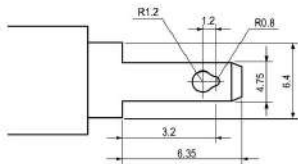

≡ Quick Connect Tab #187 / Soldering t=0.5