

Single Phase Zero Switching

KSRT Series

Part Number Description

KSRT	①	②	③	④		
① Control Voltage	D : 4 ~ 32VDC	A : 90 ~ 265VAC				
② Output Type	S : Single Phase	D : DC				
③ Load Current	010 : 10A	015 : 15A	020 : 20A	025 : 25A	030 : 30A	040 : 40A
④ Load Voltage	2 : 90 ~ 240VAC		4 : 90 ~ 480VAC			

General Specification

► General Ratings

Insulation Resistance	100MΩ / 500VDC(between Terminal and Case)
Dielectric Strength	3000VAC(50/60Hz 1minute)
Vibration Resistance	10 ~ 55Hz, amplitude : 1.5mm,x,y,z each axis 2hour
Shock Withstand	1000 m/s ² ,x,y,z each axis 3times)
Storage Temperature	-30°C ~ 90°C (with no icing or condensing)
Temperature Ambient	-25°C ~ 70°C (with no icing or condensing)
Ambient Humidity	45 ~ 85% R.H (no condensing)

☞ Heatsink Recommendations

- We recommend that solid state relay modules be mounted to a heatsink sufficient to maintain the module's base temperature at less 85°C under worst case ambient temperature and load conditions.
- The module should be mounted to the heatsink using two#10 screws.

Part Number		DS0102	DS0152	DS0202	DS0252	DS0302	DS0402		
DC Input AC Output (90 ~ 240VAC)	Input Ratings	Rated Control Voltage		4 ~ 32VDC					
		Pick-up Voltage		3VDC Min.					
		Drop-out Voltage		Max. 1.5VDC					
		Input Current		3 ~ 35mA					
	Output Ratings	Rated Load Voltage		90 ~ 240VAC					
		Repetitive Blocking Voltage(Minimum)		600V					
		Rated Load Current		10A	15A	20A	25A	30A	40A
		Frequency		47 ~ 63Hz					
		Single cycle Surge Current Resistance		170A		250A	315A		
		Output Leakage Current (Maximum)		10mA	15mA				
Output On Voltage Drop (Maximum)		1.5V							
Minimum Switching Current		1A							
Pick-up / Drop-out time		1/2 cycle Max. 1ms							







General Specification

Part Number		DS0104	DS0154	DS0204	DS0254	DS0304	DS0404	
DC Input AC Output (90 ~ 480VAC)	Rated Control Voltage				4 ~ 32VDC			
	Input Ratings	Pick-up Voltage				Min. 3VDC		
		Drop-out Voltage				Max. 1.5VDC		
		Input Current				3 ~ 35mA		
	Output Ratings	Rated Load Voltage				90 ~ 480VAC		
		Repetitive Blocking Voltage(Minimum)	800V				1200V	
		Rated Load Current	10A	15A	20A	25A	30A	40A
		Frequency				47 ~ 63Hz		
		Single cycle Surge Current Resistance	170A		250A		350A	370A
		Output Leakage Current (Maximum)				20mA		
Output On Voltage Drop (Maximum)		1.3V	1.6V			1.8V		
Minimum Switching Current					1A			
Pick-up / Drop-out time					1/2 cycle Max. 1ms			
Part Number		AS0102	AS0152	AS0202	AS0252	AS0302	AS0402	
AC Input AC Output (90 ~ 240VAC)	Rated Control Voltage				90 ~ 265VAC			
	Input Ratings	Pick-up Voltage				Min. 72VAC		
		Drop-out Voltage				Max. 60VAC		
		Input Current				Max. 15mA		
	Output Ratings	Rated Load Voltage				90 ~ 240VAC		
Repetitive Blocking Voltage(Minimum)					600V			
Rated Load Current		10A	15A	20A	25A	30A	40A	
Frequency					47 ~ 63Hz			
Single cycle Surge Current Resistance		170A		250A	315A			
Output Leakage Current (Maximum)		10mA				15mA		
Output On Voltage Drop (Maximum)					1.5V			
Minimum Switching Current				1A				
Pick-up / Drop-out time				1/2 cycle Max. 1ms				
Part Number		AS0104	AS0154	AS0204	AS0254	AS0304	AS0404	
AC Input AC Output (90 ~ 480VAC)	Rated Control Voltage				90 ~ 265VAC			
	Input Ratings	Pick-up Voltage				Min. 72VAC		
		Drop-out Voltage				Max. 60VAC		
		Input Current				Max. 15mA		
	Output Ratings	Rated Load Voltage				90 ~ 480VAC		
Repetitive Blocking Voltage(Minimum)		800V				1200V		
Rated Load Current		10A	15A	20A	25A	30A	40A	
Frequency					47 ~ 63Hz			
Single cycle Surge Current Resistance		170A		250A		350A	370A	
Output Leakage Current (Maximum)					20mA			
Output On Voltage Drop (Maximum)		1.3V		1.6V		1.8V		
Minimum Switching Current				1A				
Pick-up / Drop-out time				1/2 cycle Max. 1ms				

Single Phase Zero Switching

KSRT Series

Product Selection

	Control Voltage	Output Voltage Type	Load Current	Load Voltage	Part Number			
	4 ~ 32VDC	Single phase AC	10A	90 ~ 240VAC	KSRT-DS0102			
			15A		KSRT-DS0152			
			20A		KSRT-DS0202			
			25A		KSRT-DS0252			
			30A		KSRT-DS0302			
			40A		KSRT-DS0402			
						10A	90 ~ 480VAC	KSRT-DS0104
						15A		KSRT-DS0154
						20A		KSRT-DS0204
						40A		KSRT-DS0404
	90 ~ 264VAC	Single phase AC	10A	90 ~ 240VAC	KSRT-AS0102			
			15A		KSRT-AS0152			
			20A		KSRT-AS0202			
			25A		KSRT-AS0252			
			30A		KSRT-AS0302			
			40A		KSRT-AS0402			
						10A	90 ~ 480VAC	KSRT-AS0104
						15A		KSRT-AS0154
						20A		KSRT-AS0204
						40A		KSRT-AS0404

Dimension

unit : mm

KSRT 10A, 15A

KSRT 20A, 25A, 30A (without KSRT-DS0304)

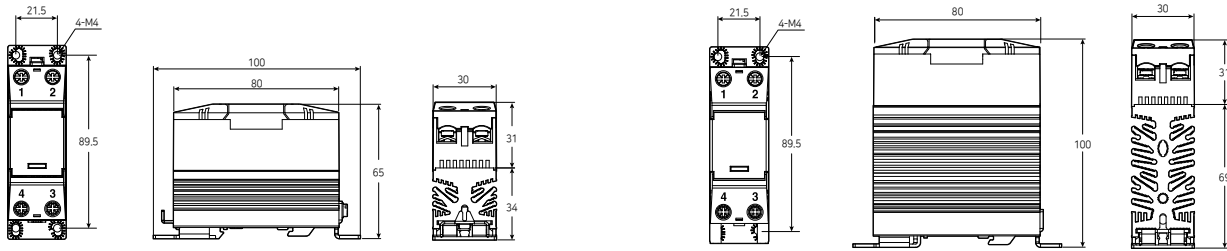

KSRT 40A, KSRT-DS0304

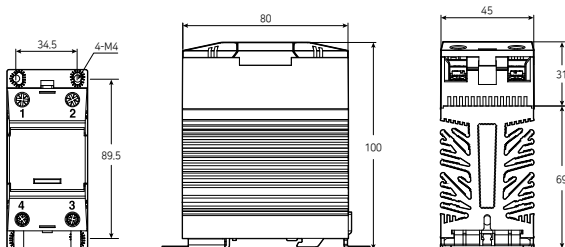

Technical Data

Input Current & Input Impedance

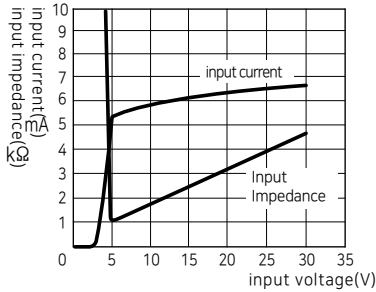

Ambient Temperature-Load Current

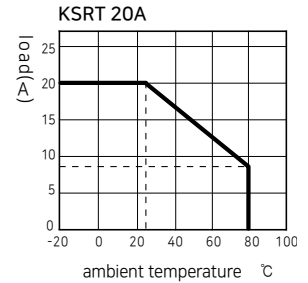
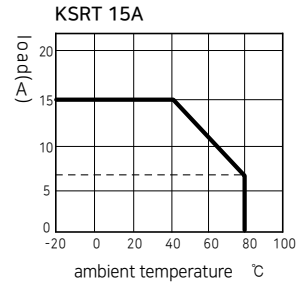
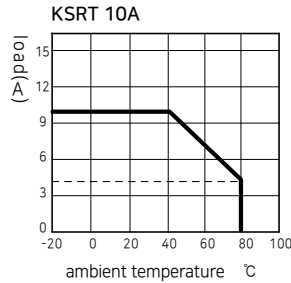

Heatsink Type Vs Heatsink + Fan Type

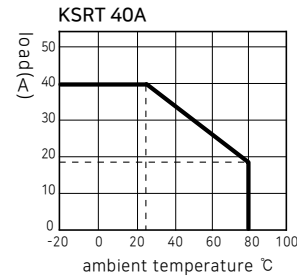
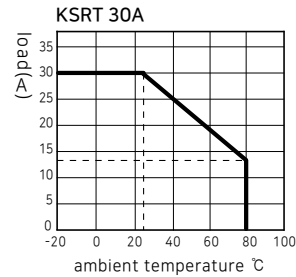
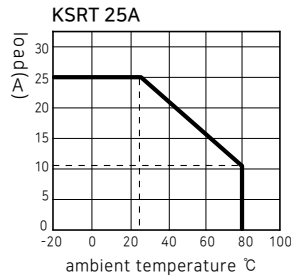
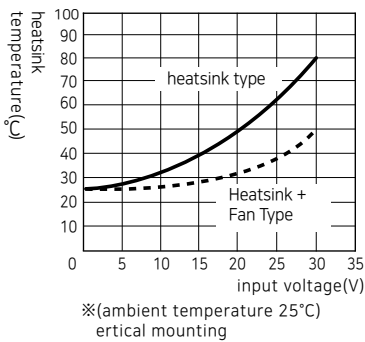

- The radiator fan reduces the radiator temperature up to 35 ~ 40 % (ambient temperature of 25°C / vertically attached)
- In the design process, note that the load current characteristic diminishes with the increase in the ambient temperature.
- With the high-voltage type, design the system at 80 % of the rating or less.
- The device life is prolonged with proper temperature circumstance.

Mounting

Vertical Mounting

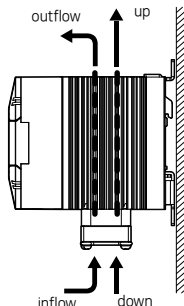

Horizontal Mounting

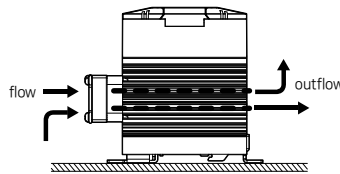

Panel Mounting

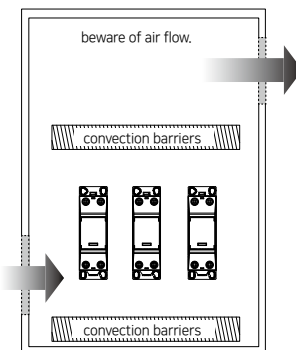

- Direct the fan in the lower direction for vertical installation, and in the air inlet direction for horizontal direction.
- If the horizontally mounted device does not have an integrated fan, use it at 50% of the rated current or less.
- Pay attention to the increase in the ambient temperature from the heating of the device. Especially when mounting the device in the panel, be sure to install a fan for sufficient ventilation.
- Remove any obstacles for air flow around the air inlet and outlet.

Single Phase Zero Switching

KSRT Series

Mounting

KSRT Mounting Distance

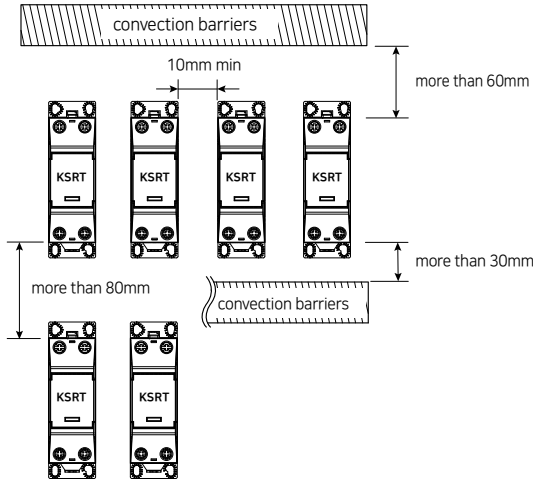

- The heat radiation effect decreases when there is not much room. Limit the load current below the rating.
- Install the device as far as possible from a heating unit, if there is any.
- Allow the longest distance possible between the device and other unit.

EMC Wiring

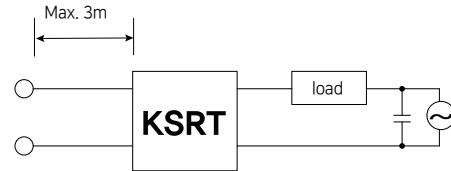

- Connect the film condenser at the two load output ends.
- Limit the input wire length Max. 3m.

Time Loss

- Note that low voltage and current of the load increases time loss. Check if any problem exists.

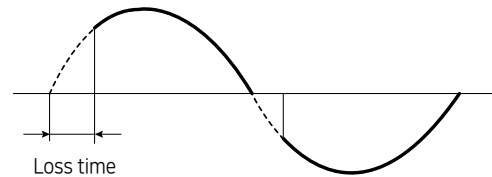

Terminal

- When using crimp terminals, refer to the terminal specifications for terminal part spaces.

KSRT Input Terminal

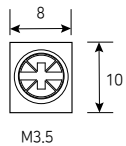

KSRT Load Terminal

10 ~ 30A

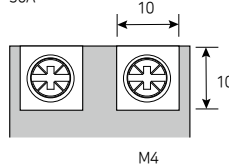

40A

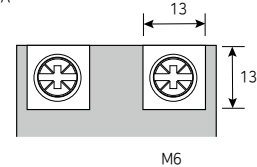

Terminal Specification

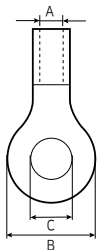

	Model	Bolt	A	B	C	Terminal	Wire Ø	Torque Max N·m
LOAD	10 ~ 30	M4.0	3.0	8.3	4.3	3.5-4.0	2.0	1.2
	40	M6.0	5.8	12.0	6.4	14.0-6.0	4.2	2.5
INPUT	All	M3.5	2.3	6.6	3.7	2.0-3.5	2.0	0.8

※ input terminal : ⊕ red, ⊖ black

- Be sure to conduct wiring only after switching off the power.
- Select the wire size according to the current.
- Tighten screws firmly at the specified torques.
- Applying an excessive torque may cause the screw to fail. Pay attention especially when using an electric driver.
- The screw at the output terminal must not be loosened. Abnormal heating at the terminal may cause fire.
- After wiring, be sure to lock the terminal safety cover in the closed position to prevent an electric shock or a short circuit.