

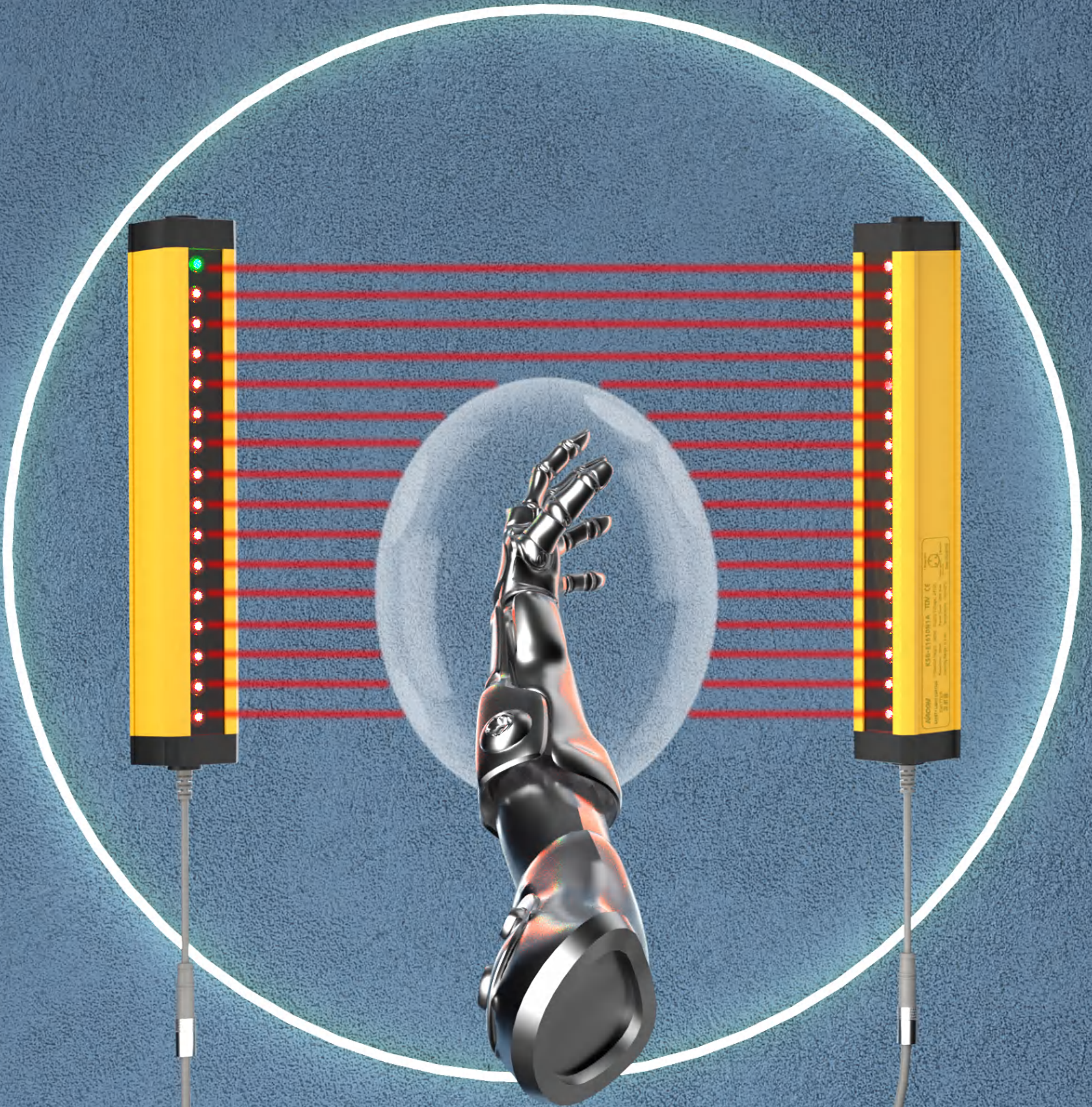

Kacon Safety Light Curtain



Keeping production sites safe and secure

Catalog Overview



- **Application Scenario Display** ----- P03
- **Features Introduction** ----- P04
- **Explanation of Terminology** ----- P05
- **European Industrial Safety Standards** ----- P06
- **Product Selection** ----- P07
- **Signal Difference Between NPN and PNP** ----- P08
- **Product Features** ----- P09
- **Drawing & Naming** ----- P10
- **Product Technical Specification** ----- P11
- **Wiring Diagram** ----- P12
- **Specification Summary Table** ----- P13
- **Accessories** ----- P14

Application scenario display

Electromagnetic safety door lock switch



- ▶ Various contact configurations with locking function
- ▶ Wide range of applications with a variety of operating keys
- ▶ Switch head is freely selectable
- ▶ Safety door switches are generally the lowest cost solution

Emergency stop switch



- ▶ Forced disconnect design
- ▶ Silver alloy contacts
- ▶ Matching shield, flame retardant material
- ▶ Obtained S-MARK safety certification

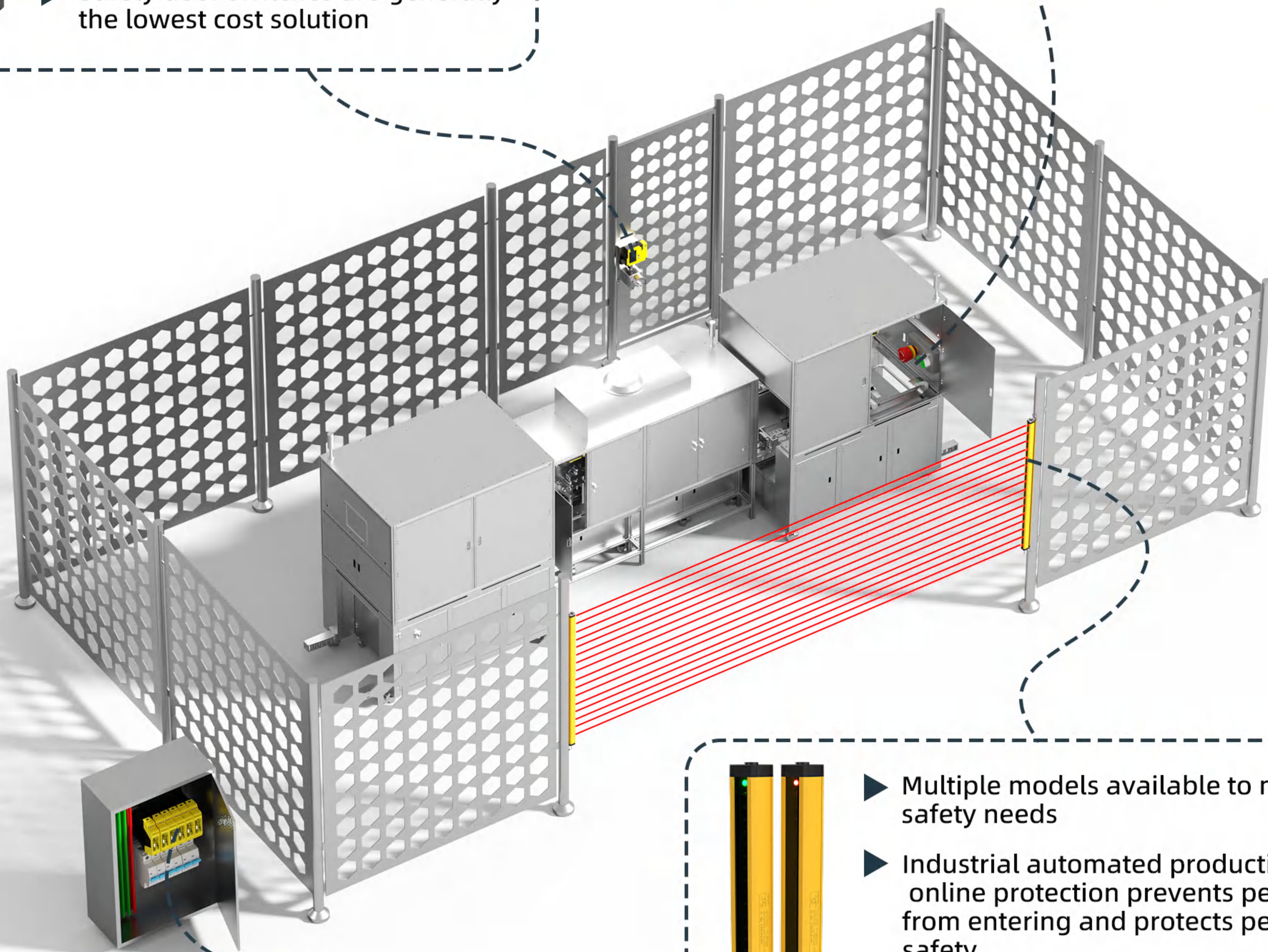

- ▶ Multiple models available to meet safety needs
- ▶ Industrial automated production line online protection prevents people from entering and protects personal safety
- ▶ Linkage with other smart devices for more efficient production and safety management.



- ▶ Suitable for monitoring and controlling various signals in industrial sites with high safety requirements.
- ▶ Multiple reset modes, multiple input types for safer use.
- ▶ Proven dual-channel safety monitoring circuit design.

Safety relay module

Safety light curtain

More safety products in development...

Light curtain characteristics

Extremely resistant to electromagnetic interference

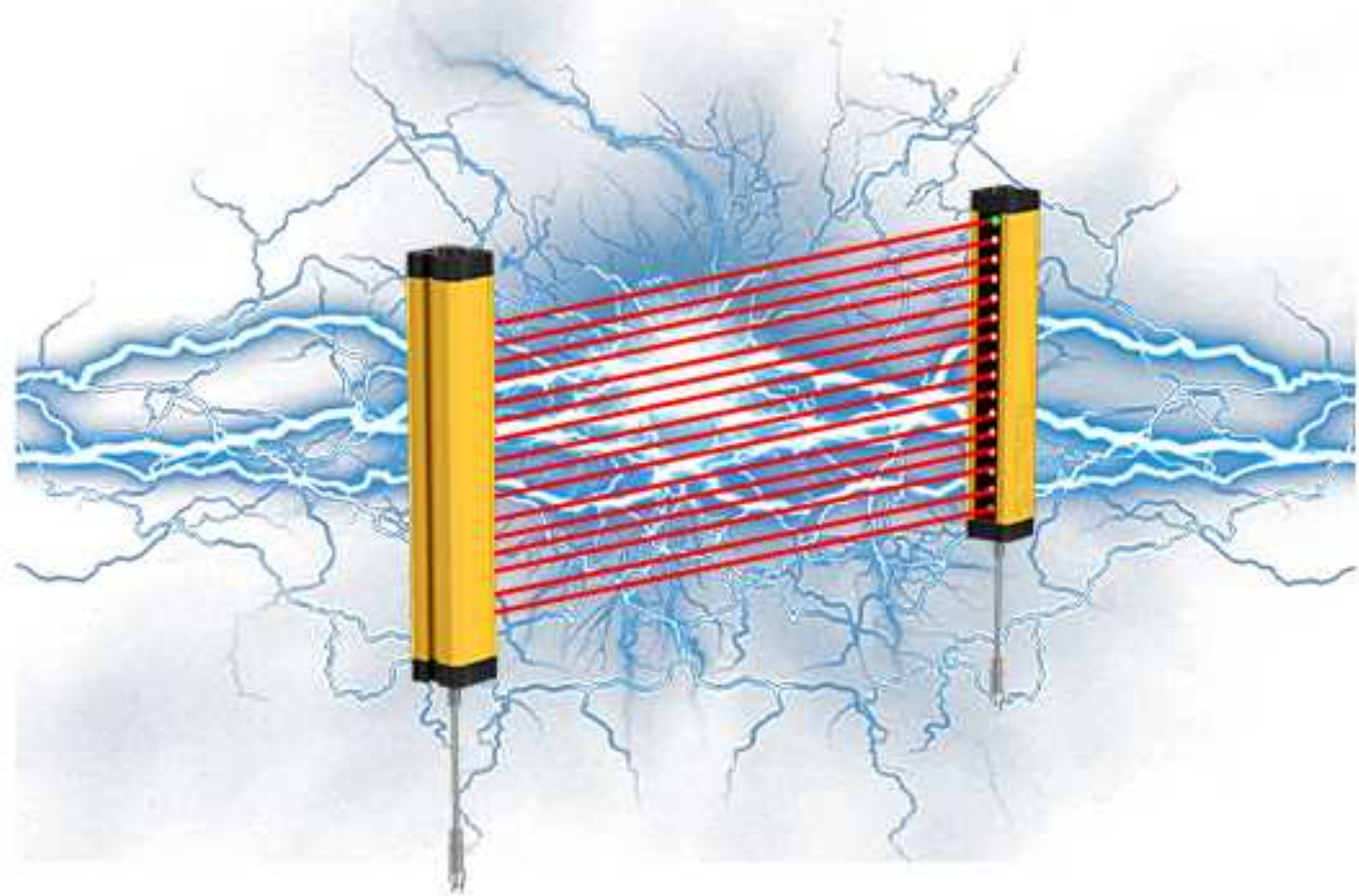

Features: through simulation and analysis, we have designed a light curtain with super anti-electromagnetic interference capability.

Solve the problem: can be a good solution to the line conduction, space conduction servo inverter electromagnetic interference, widely used and servo more, more inverters, large motors more occasions.

Extremely resistant to arc, laser, and sunlight

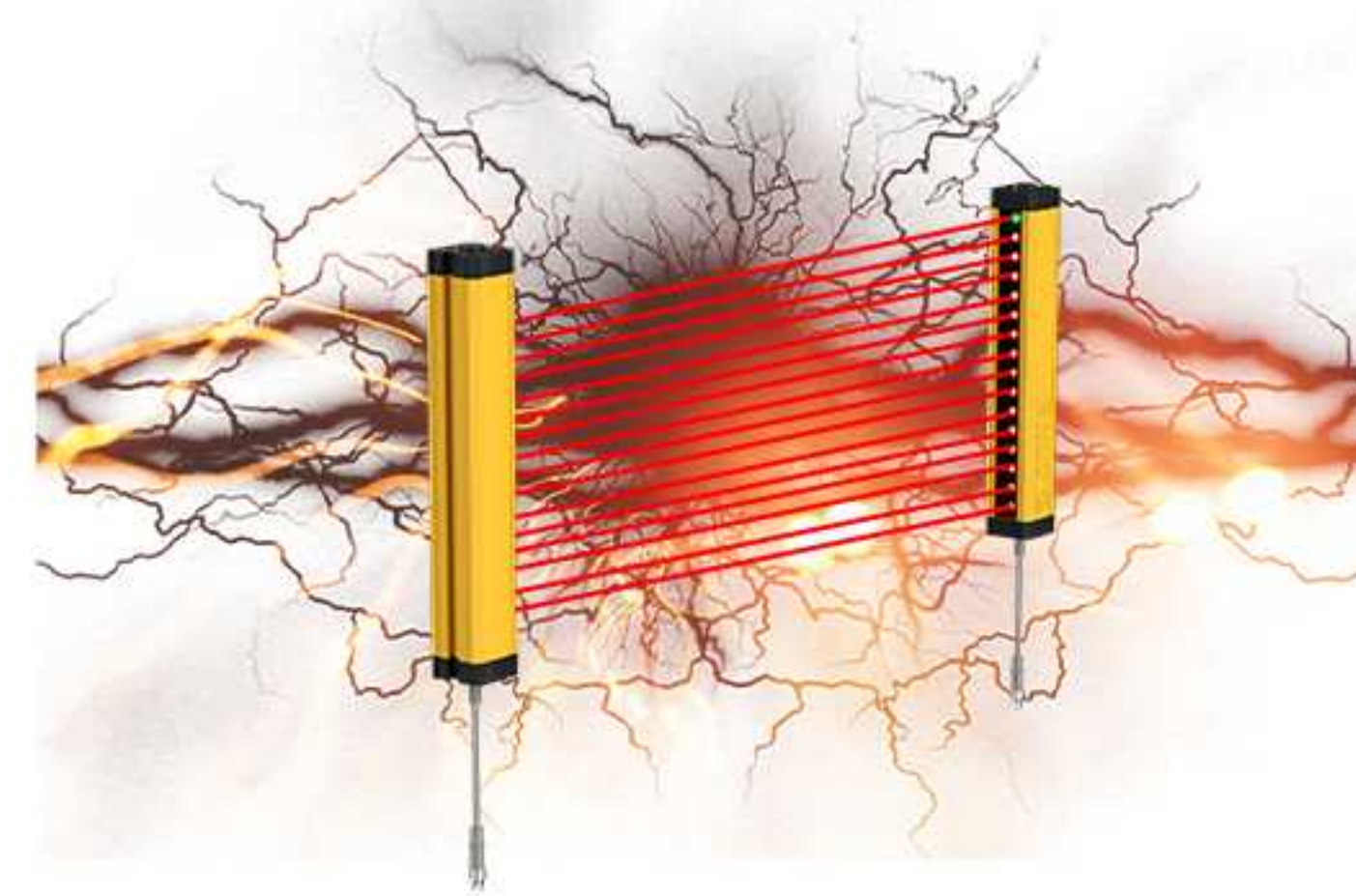

Features: precision optics, hardware and software algorithm design, with superb resistance to all kinds of optical interference.

Solve the problem: safeguard the operation safety of laser welding, has avoided the erosion of outdoor sunlight interference.

Adoption of optical synchronization technology

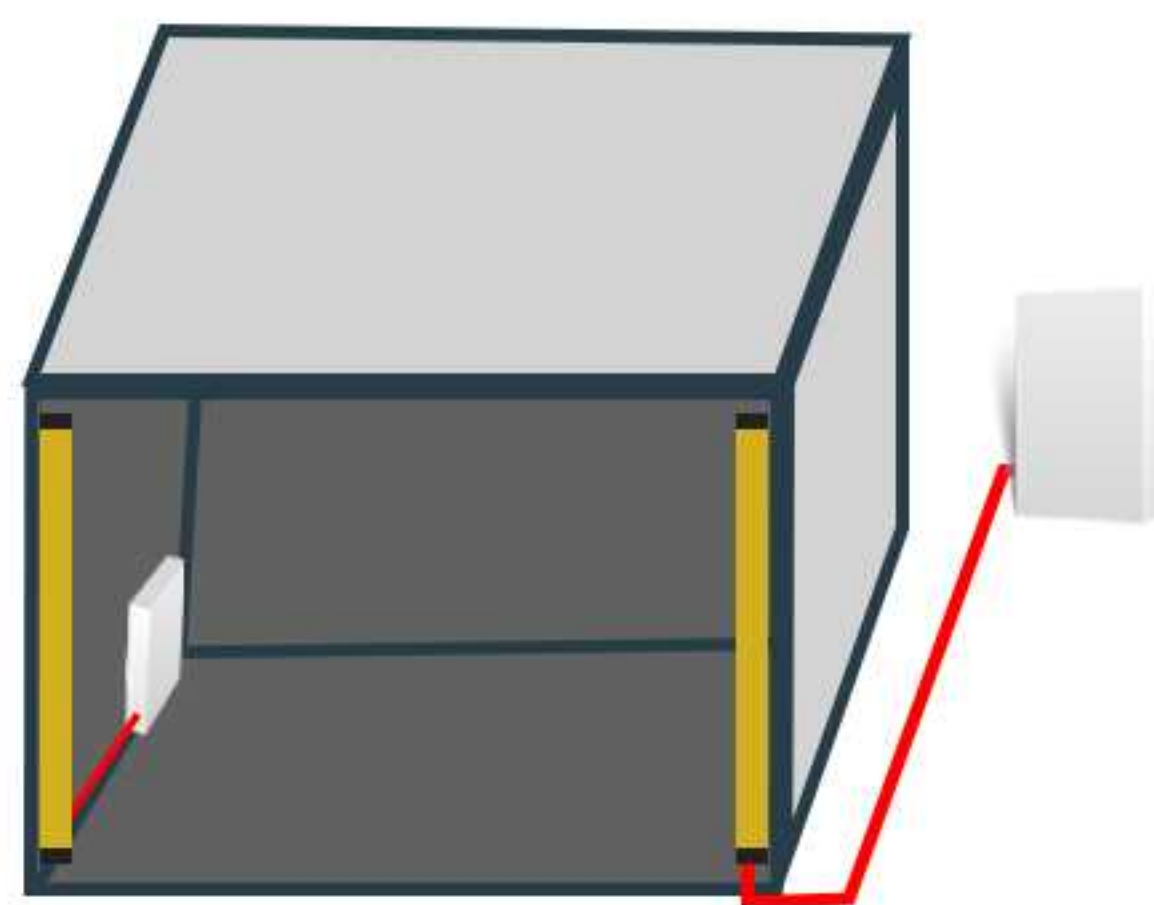

Features: There is no wiring between the transmitter and receiver.

Solve the problem: eliminate the cumbersome wiring project, especially in the use of long-distance shooting, make the wiring more simple, but also reduce the electromagnetic interference synchronization line of confusion.

Extremely responsive light curtains

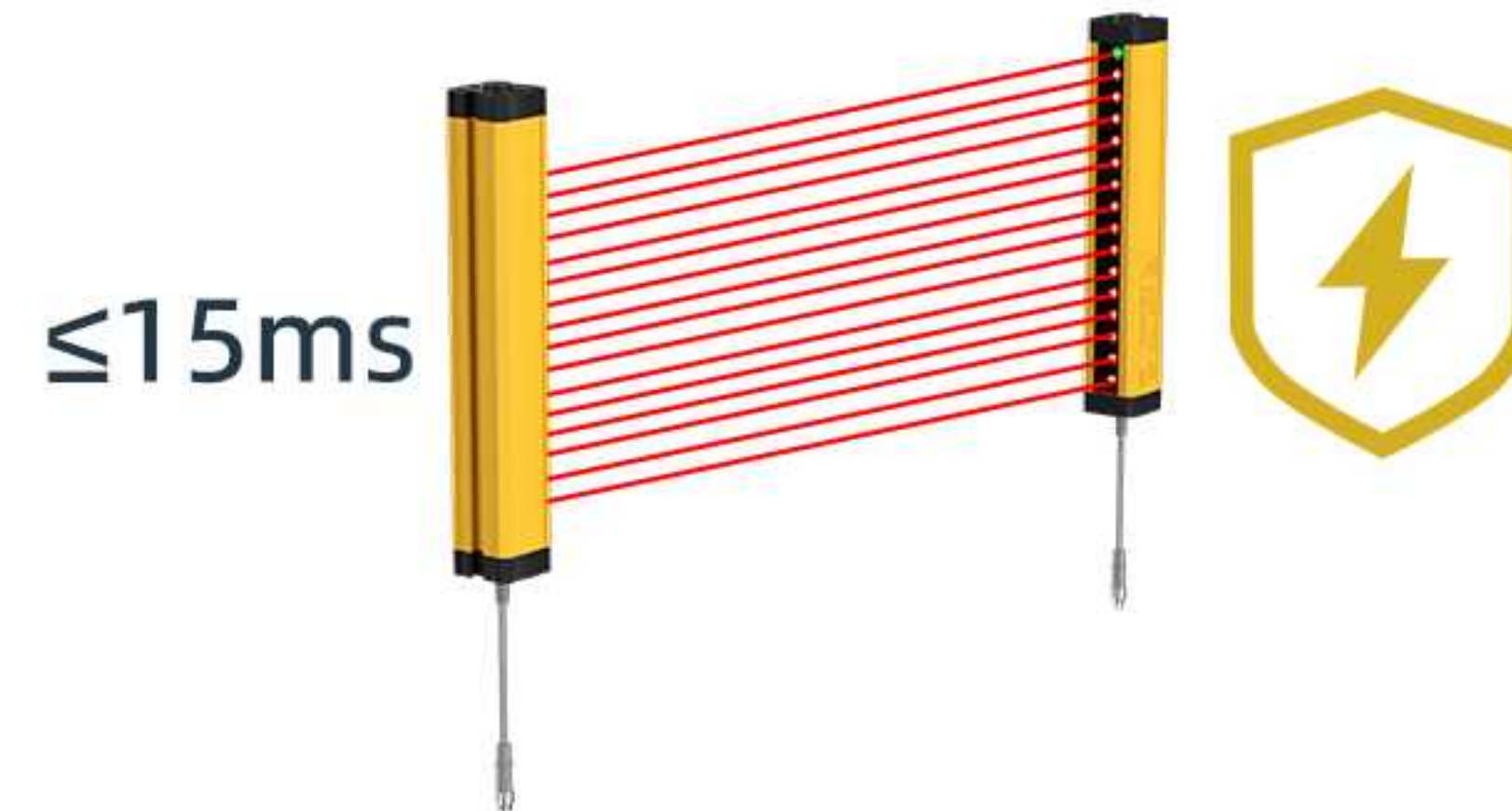

Features: the product uses the latest software algorithms to make the light curtain response time less than 15ms.

Problem solved: reduces the safety distance by more than half compared to normal light curtains, and can detect items that are fast talking their way through the light curtain.

High protection class



Features: IP65 protection level, both protection for water, can be used outdoors.

Solve the problem: Ordinary models of light curtains because of large changes in ambient temperature lead to thermal expansion and contraction of different components, the sealing effect is not ideal, the waterproof effect is very poor.

Optional waterproof aviation plug



Features: dimension design 29.3mm*29.3mm, the safety sensor can be linked with the cable wire (M12) through the aviation socket.

Problem solving: applicable to more scenarios, in line with the majority of users do not have to use the situation of the use of demand.

Explanation of professional terms

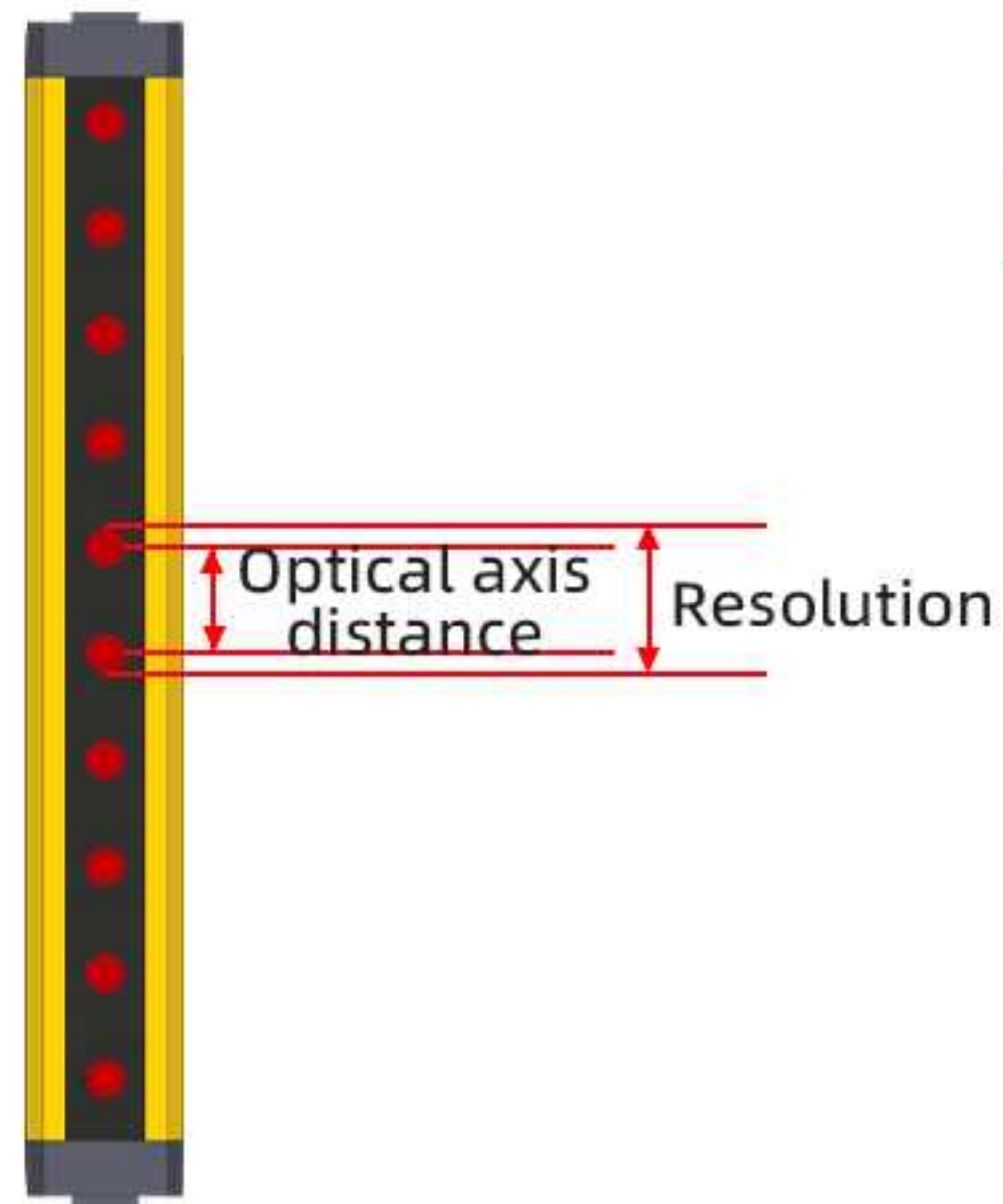

Resolution (detection capability)

Refers to the minimum size of the object detected by the light curtain whose size is the distance between the optical axis plus the width of a lens. Measurement method: Use a cylindrical object with a diameter equal to the resolution to enter and move up and down at any position on the opposite side of the light curtain, the light curtain should.

Commonly used

10mm spacing between optical axes: for protecting "fingers"

20mm spacing between optical axes: for protecting the "palms"

40mm spacing between optical axes: for protecting the "arm"

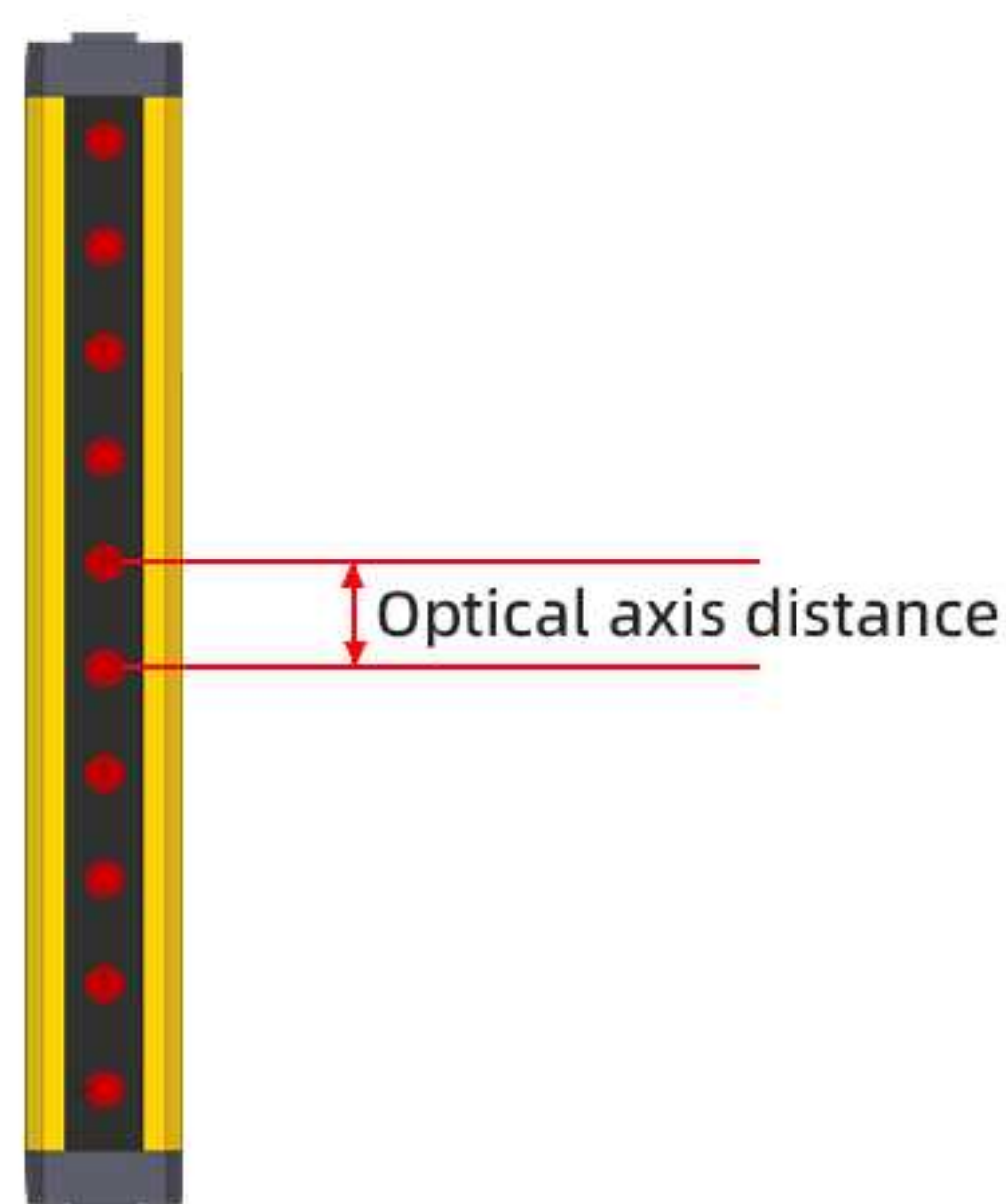

Optical axis distance

Refers to the spacing between the centerlines of two points of light remain blocked.

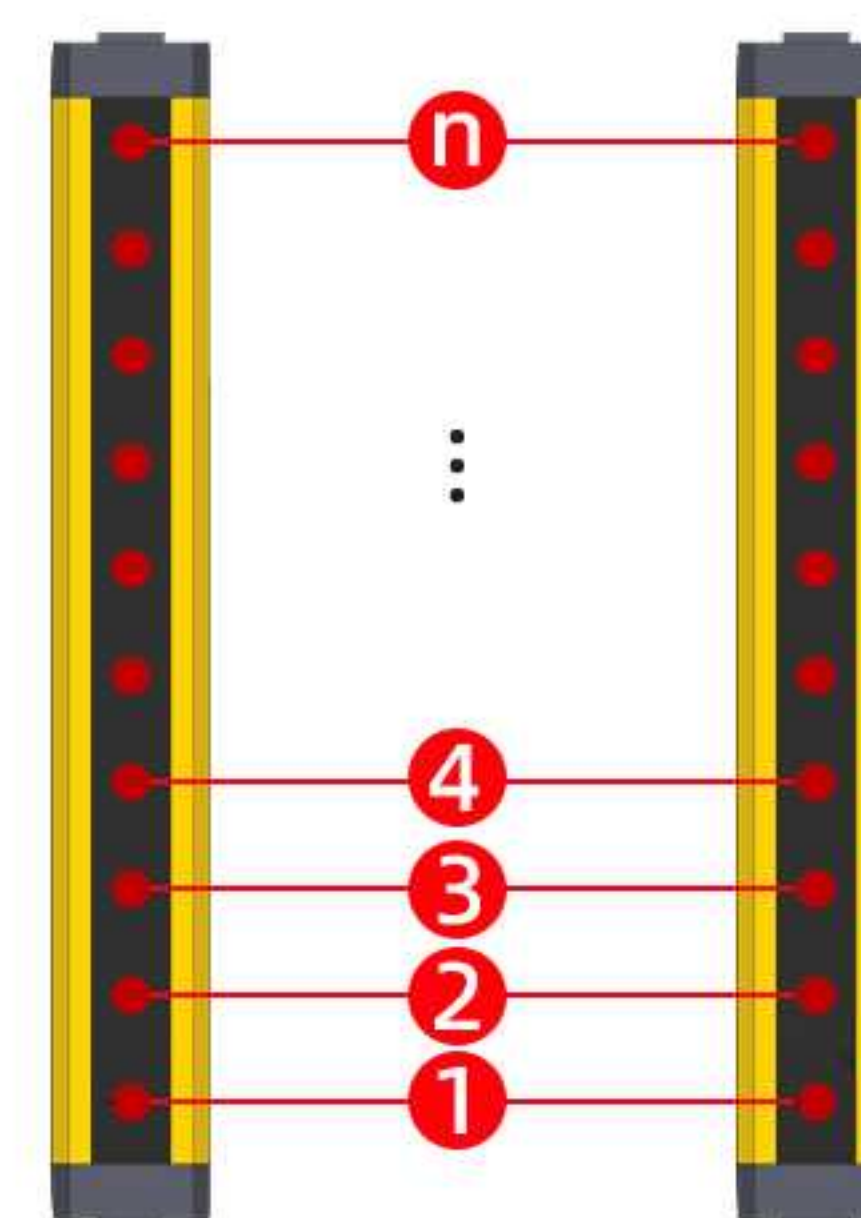

Number of optical axes

Refers to the number of optical axes formed by two corresponding beams.

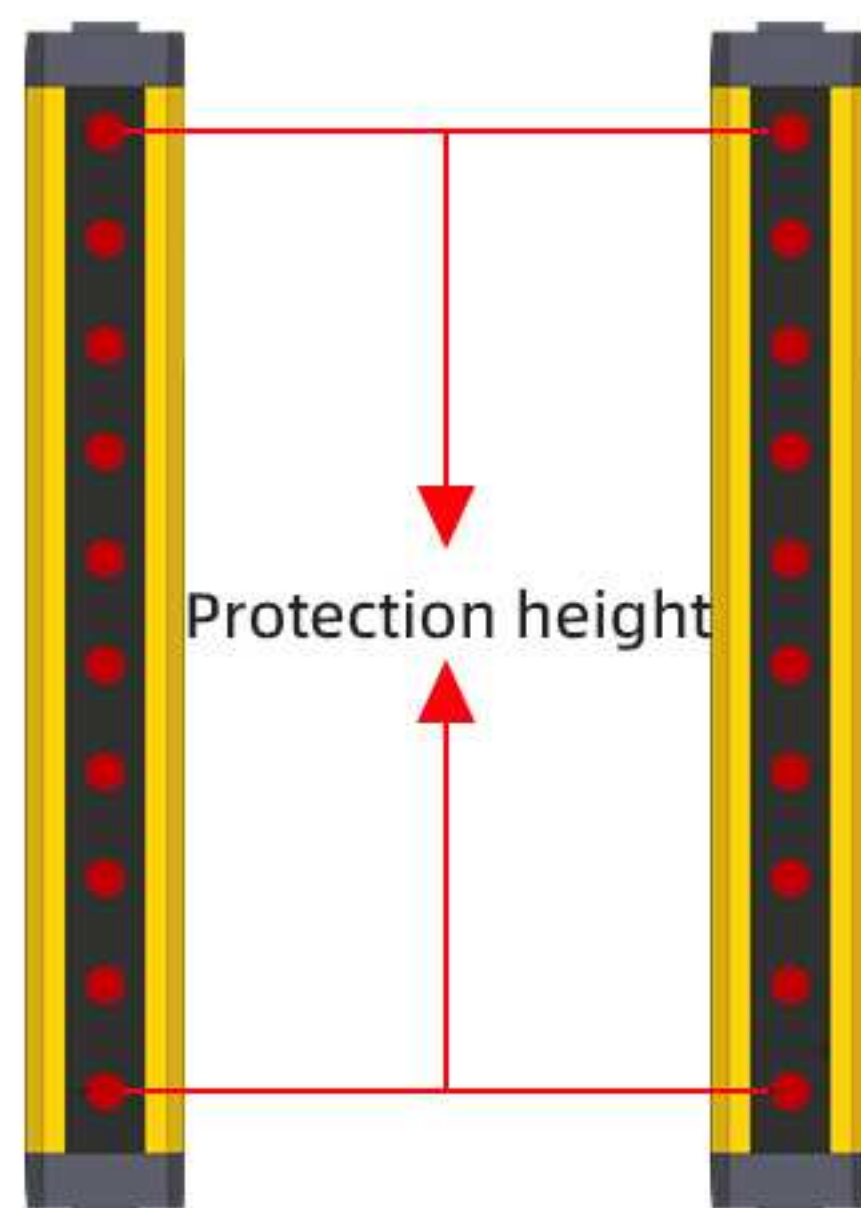

Detection height

Distance from the center of the first optical axis to the center of the last optical axis.

Protection height

Detection height + one optical axis distance up + one optical axis distance down.

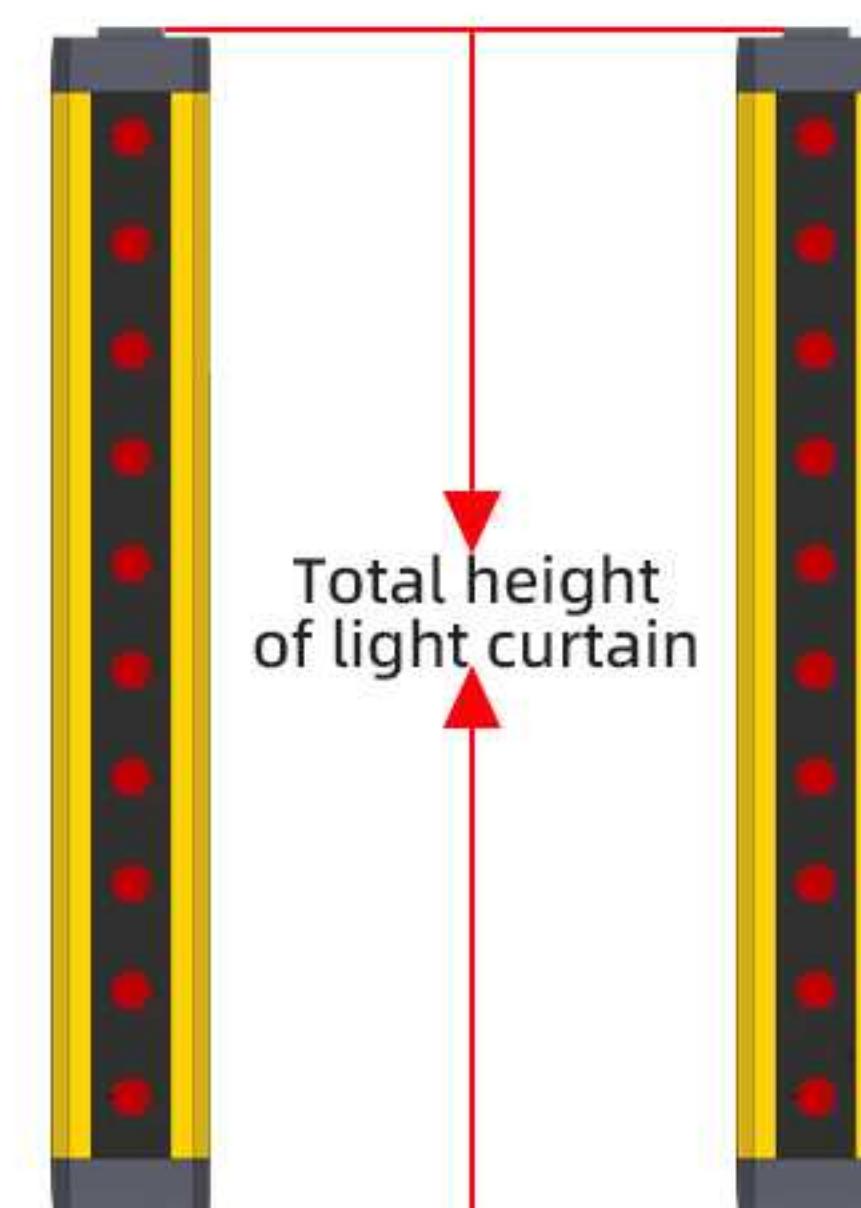

Total height of light curtain

Means the distance from the bottom to the top of the light curtain.

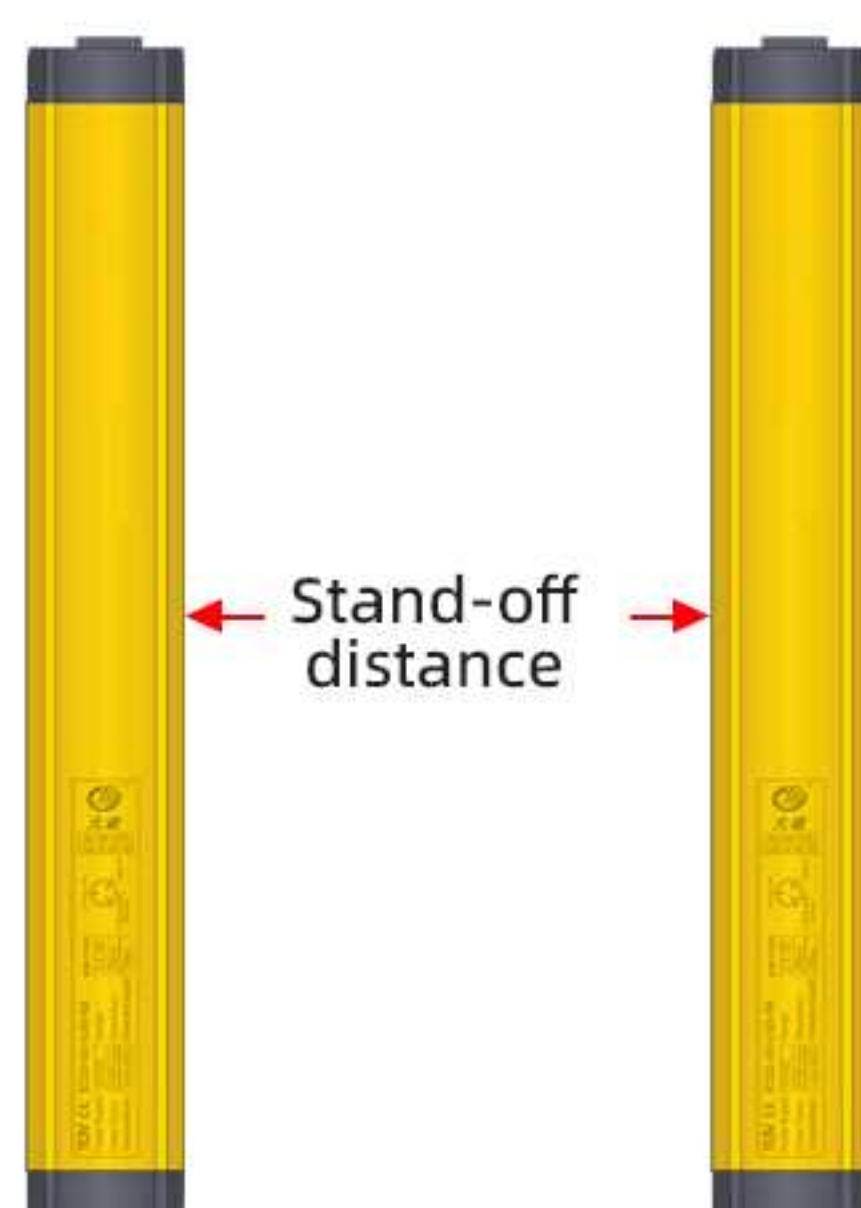

Actual installation alignment distance

Actual distance of installation between transmitter and receiver in practice.

Furthest light curtain counterpoint distance

The furthest distance from the light curtain when the light curtain is in the critical light-opposing state.

Precaution

*The light curtain must meet the following requirements: Maximum distance ≥ 1.3 times the mounting distance.

*The distances stated in this brochure are generally the applicable focusing distances of the light curtain.

European Industrial Safety Standards

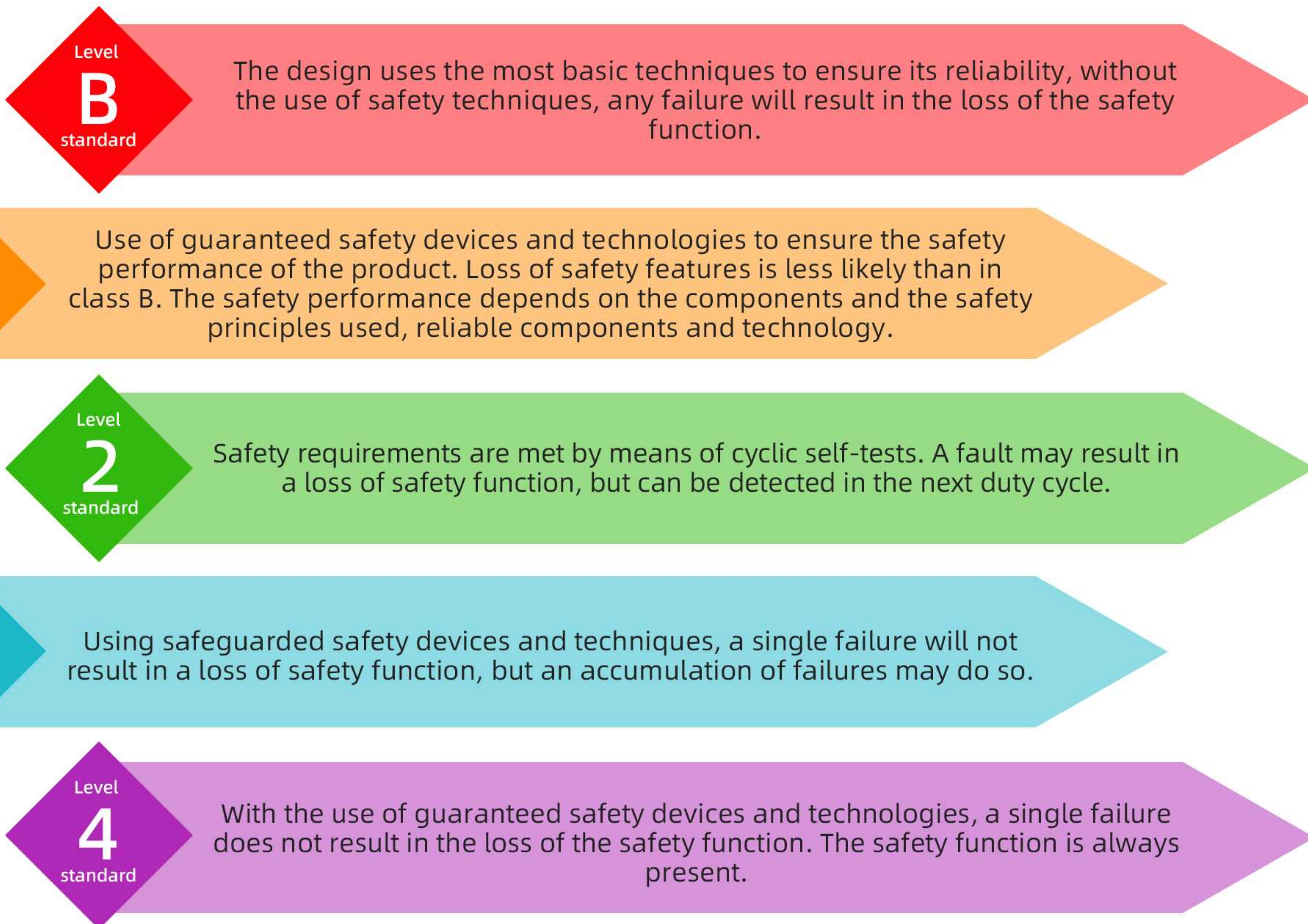

Symbols	Description of symbols	Level standard	Description of level standard
S	Degree of injury	S1	Minor injuries with natural recovery
		S2	Unrecoverable or lethal damage
F	Degree of exposure to risk	F1	Few
		F2	Possible
P	Degree of risk avoidance	P1	Can be avoided under certain circumstances
		P2	Almost impossible

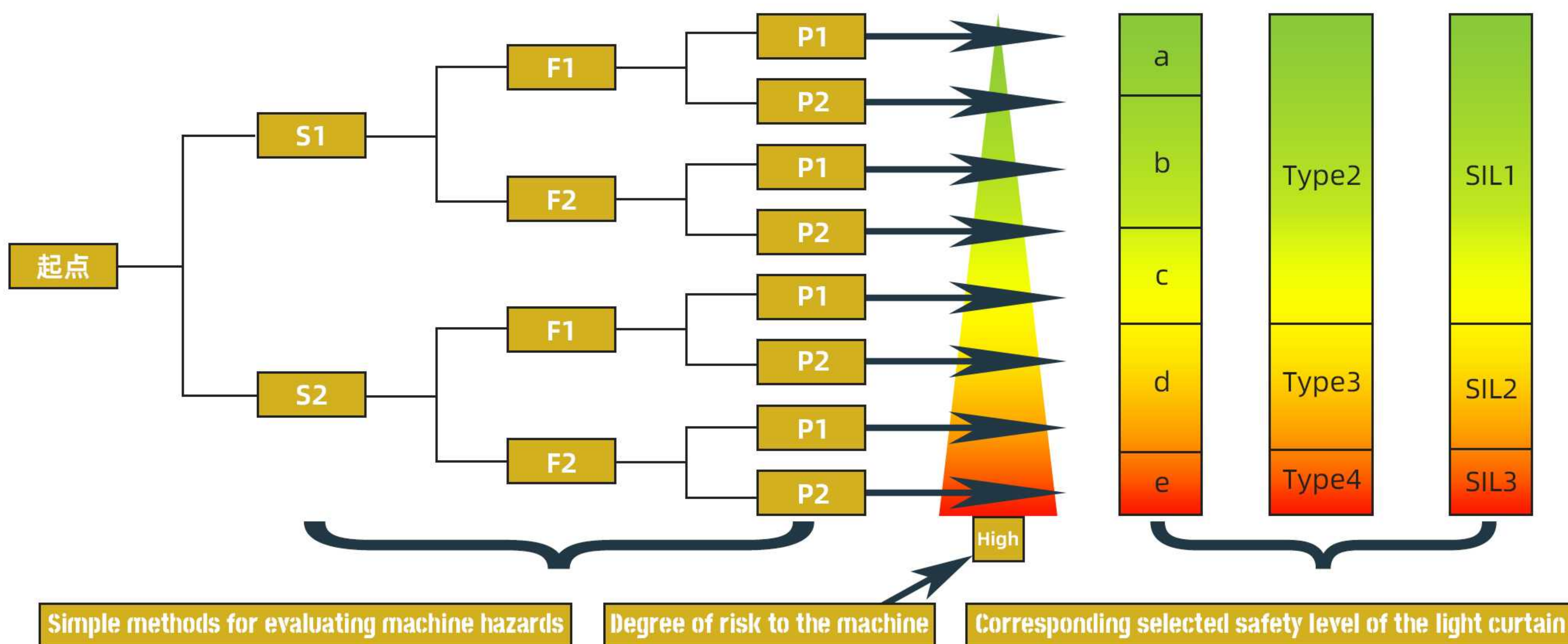

***Select level 2 for minor injuries and level 4 for serious injuries. Area sensors are not recommended for security**

Selection method

Optical axis distance

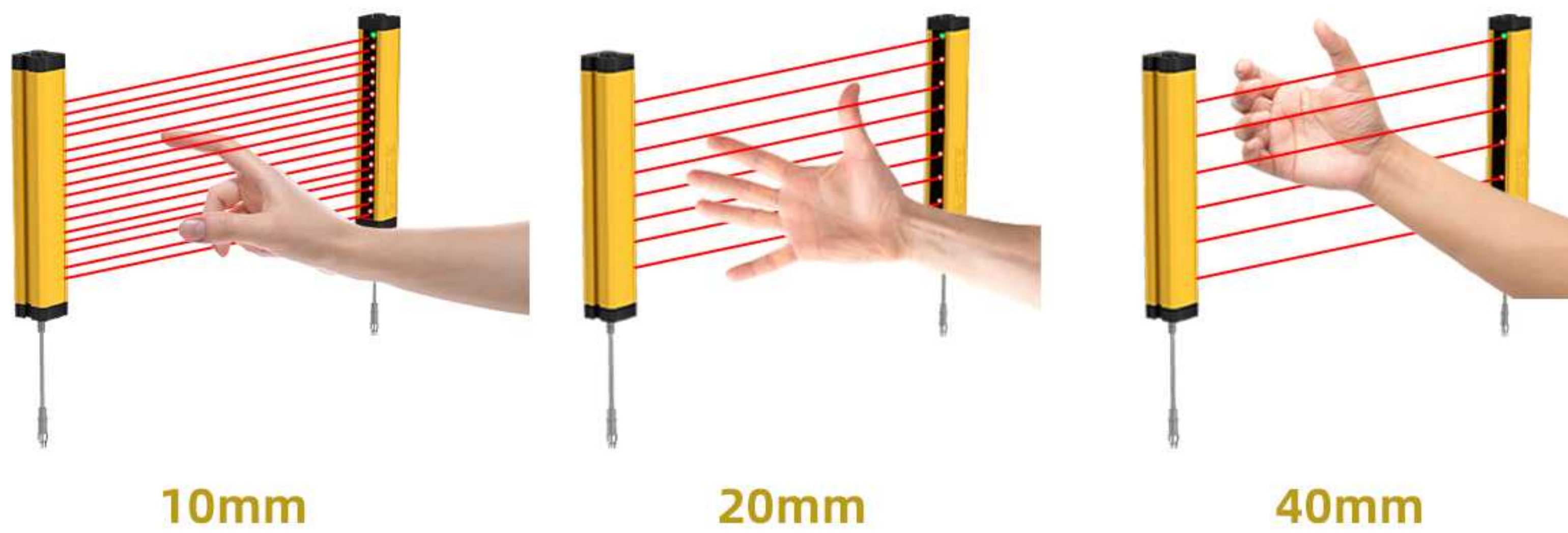

10mm

20mm

40mm

10mm: protect fingers
20mm: protect palms
40mm: protect arms

Number of optical axes

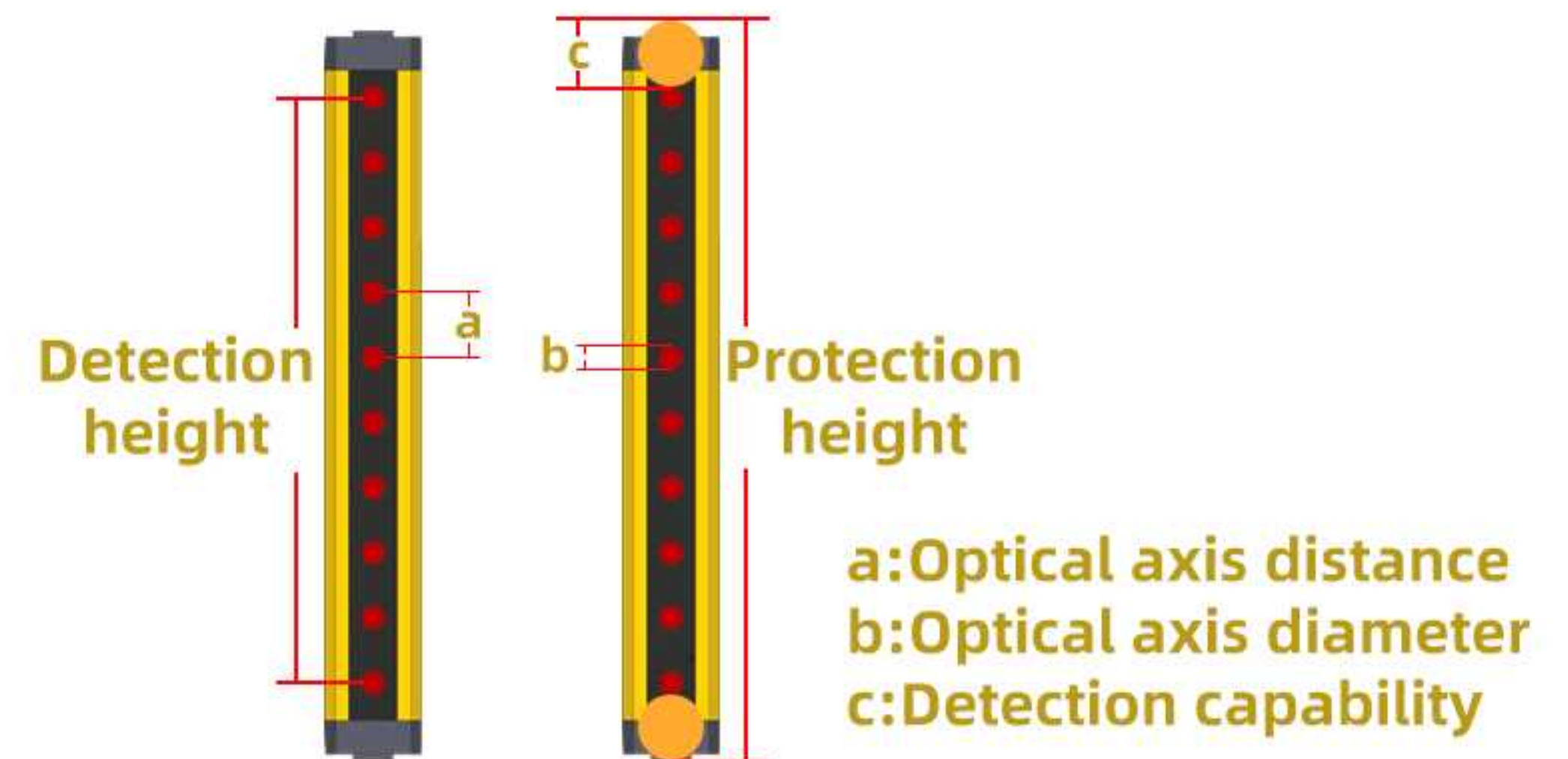

Protection height = (number of optical axes - 1) x distance between optical axes
4 points ~ 200 points in the even number of arbitrary choice

Signal output selection (actual output of the transistor in normal operation)

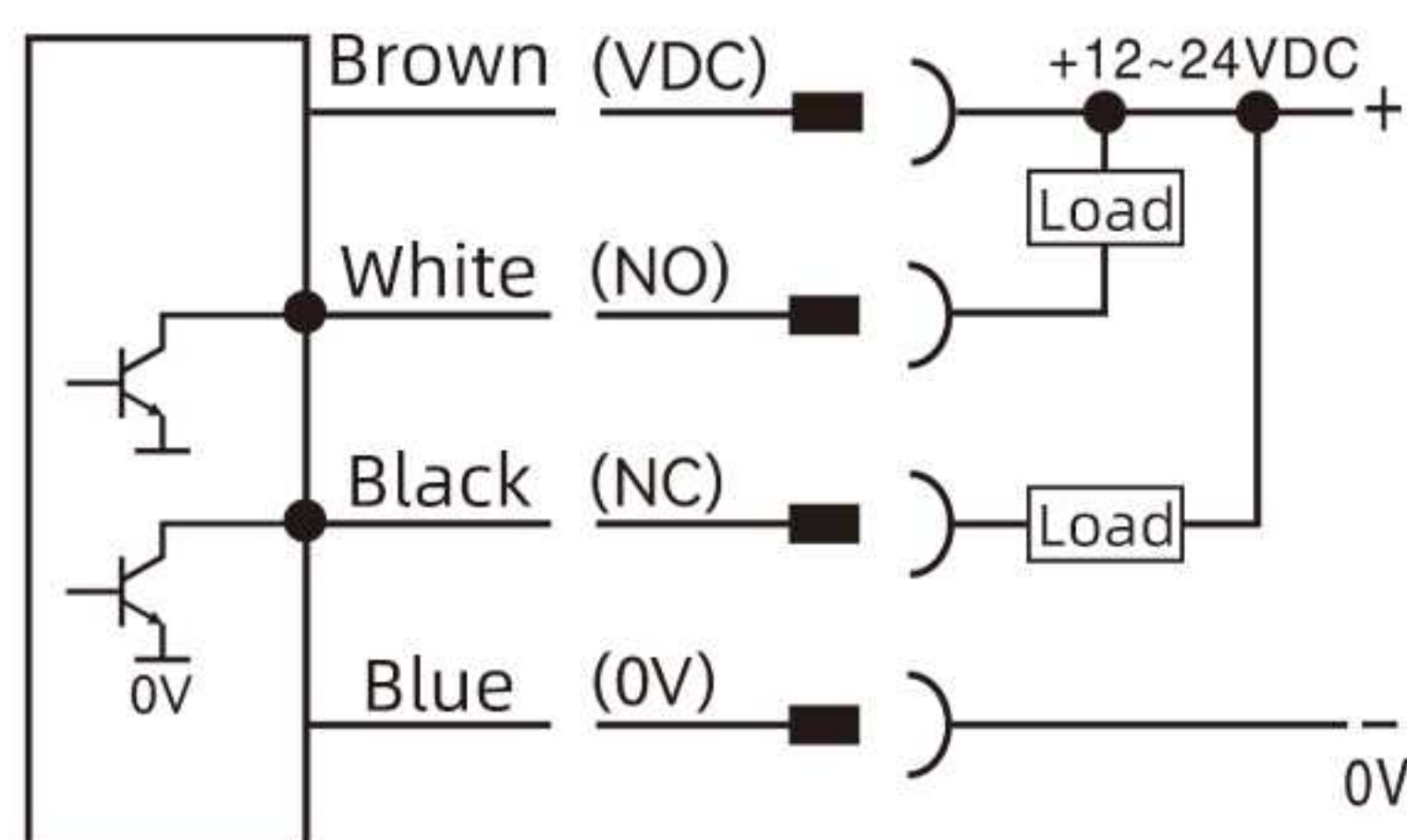

NPN NC

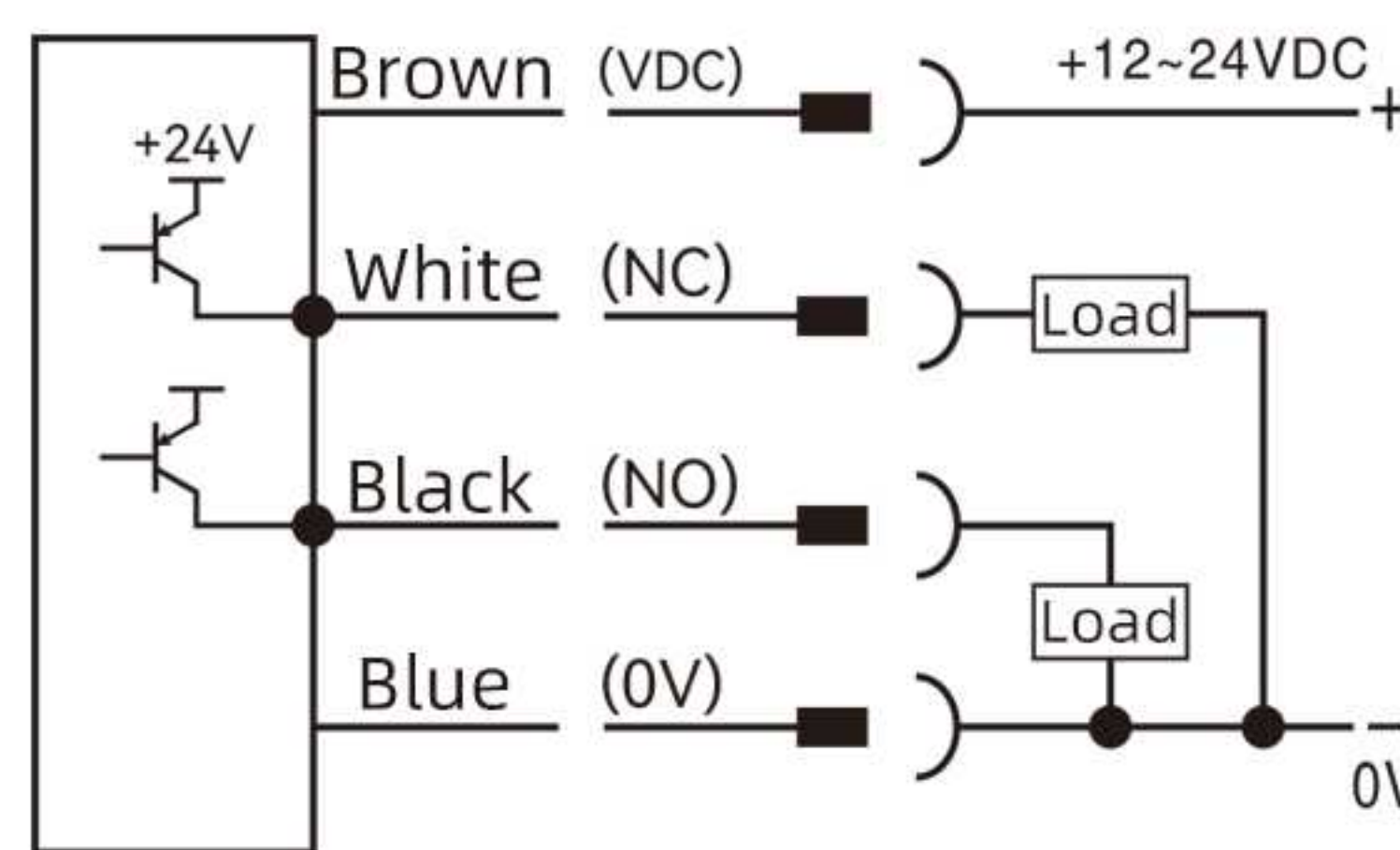

PNP (NO/NC)

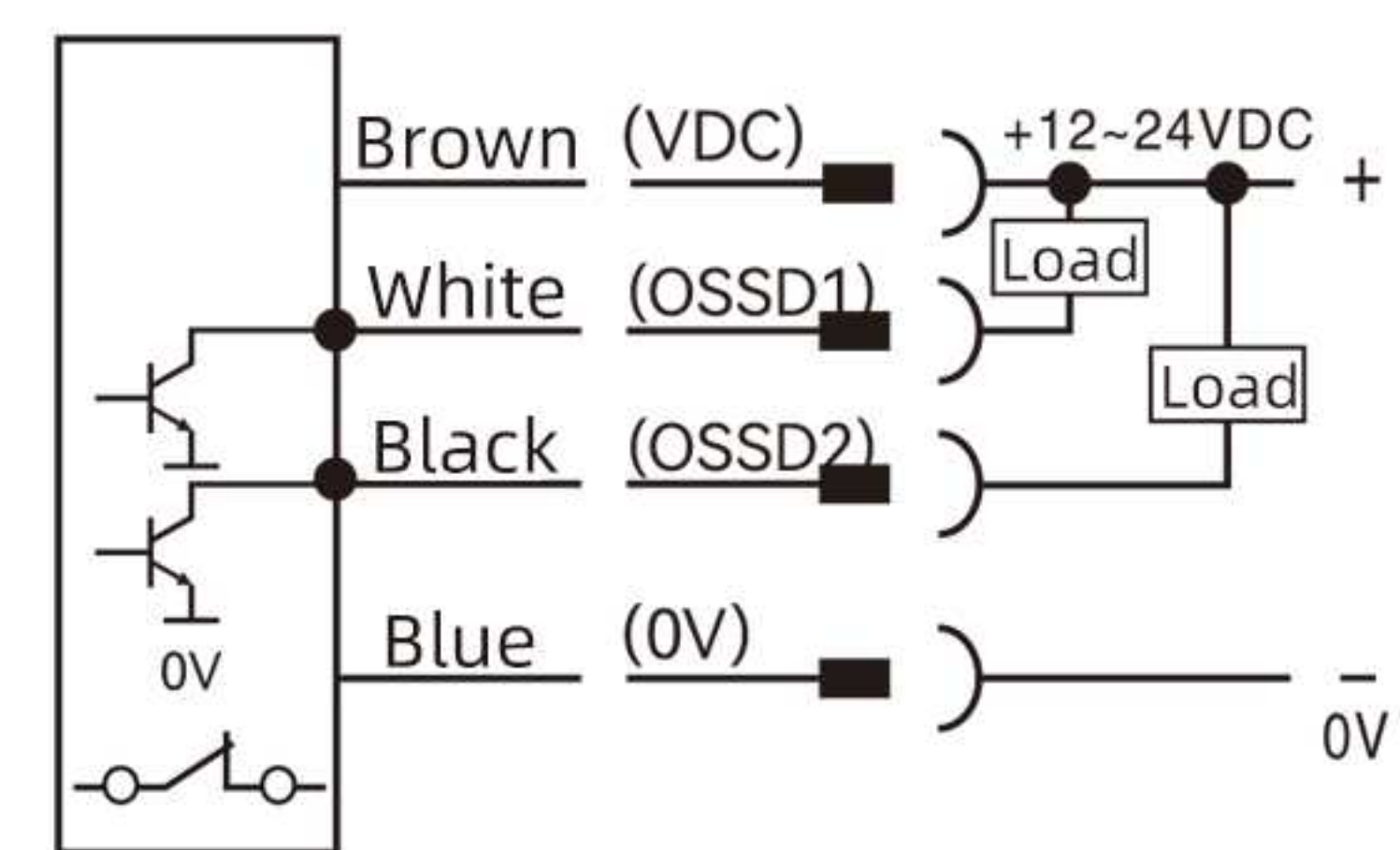

NPN NC

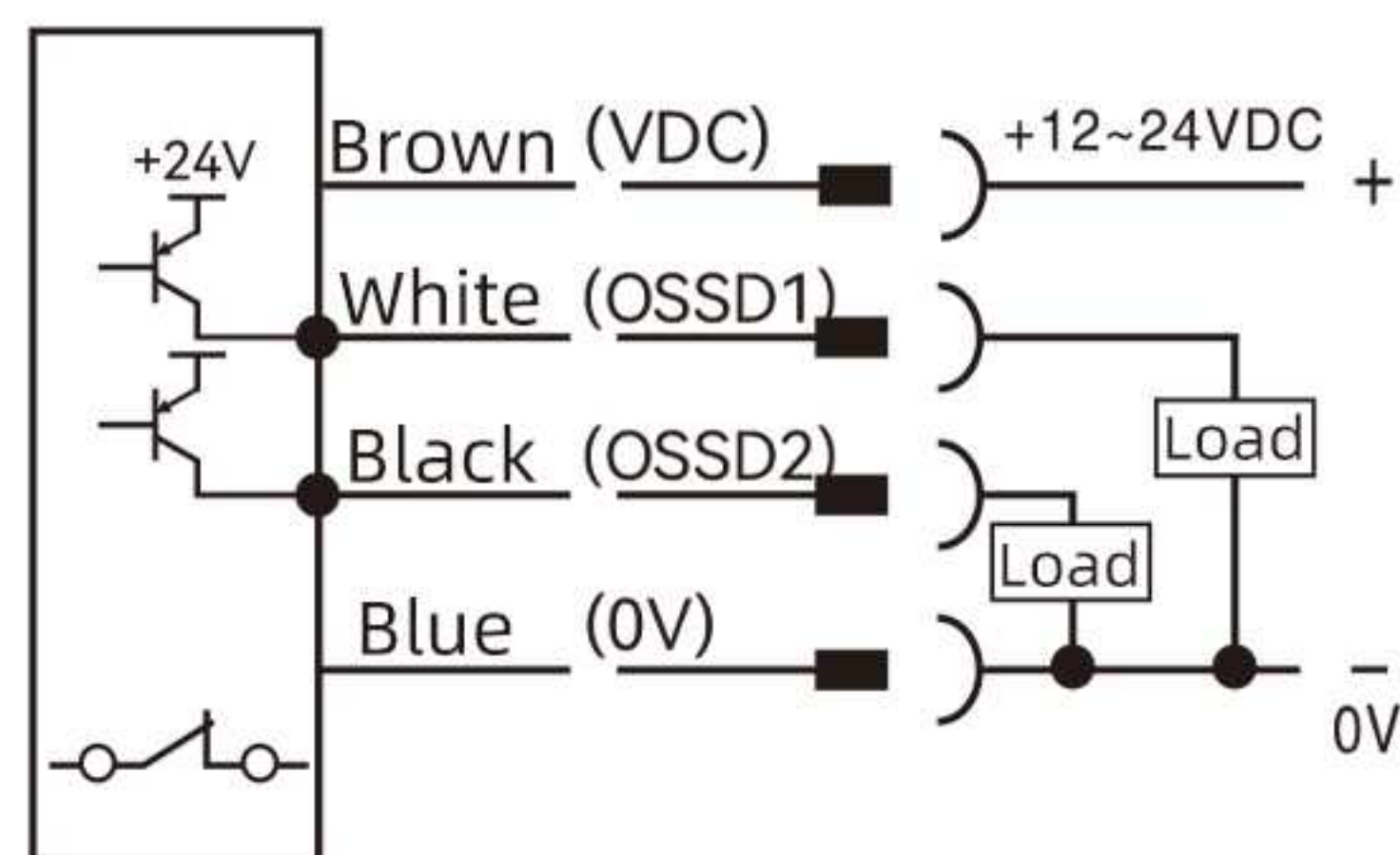

PNP NC

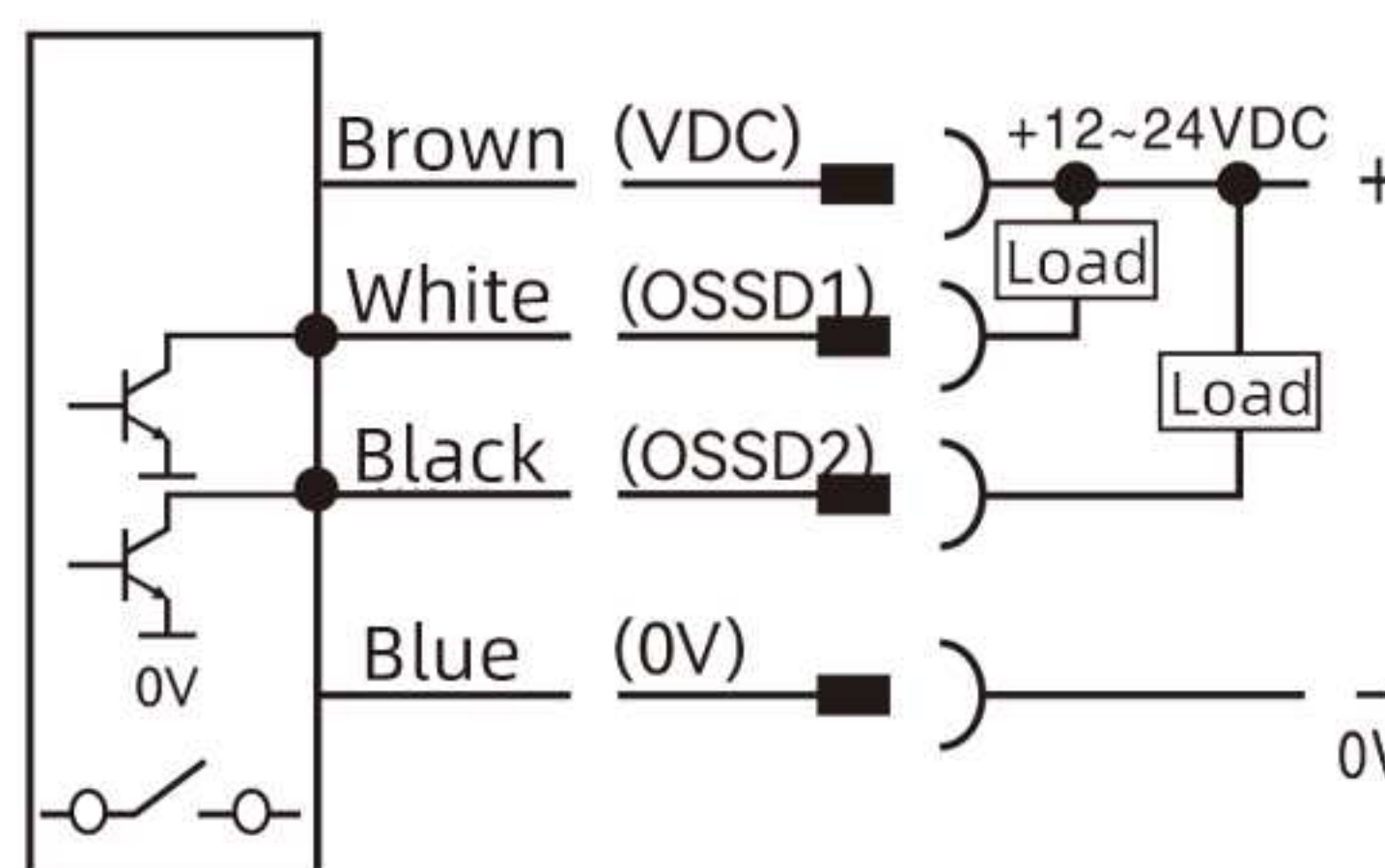

NPN NO

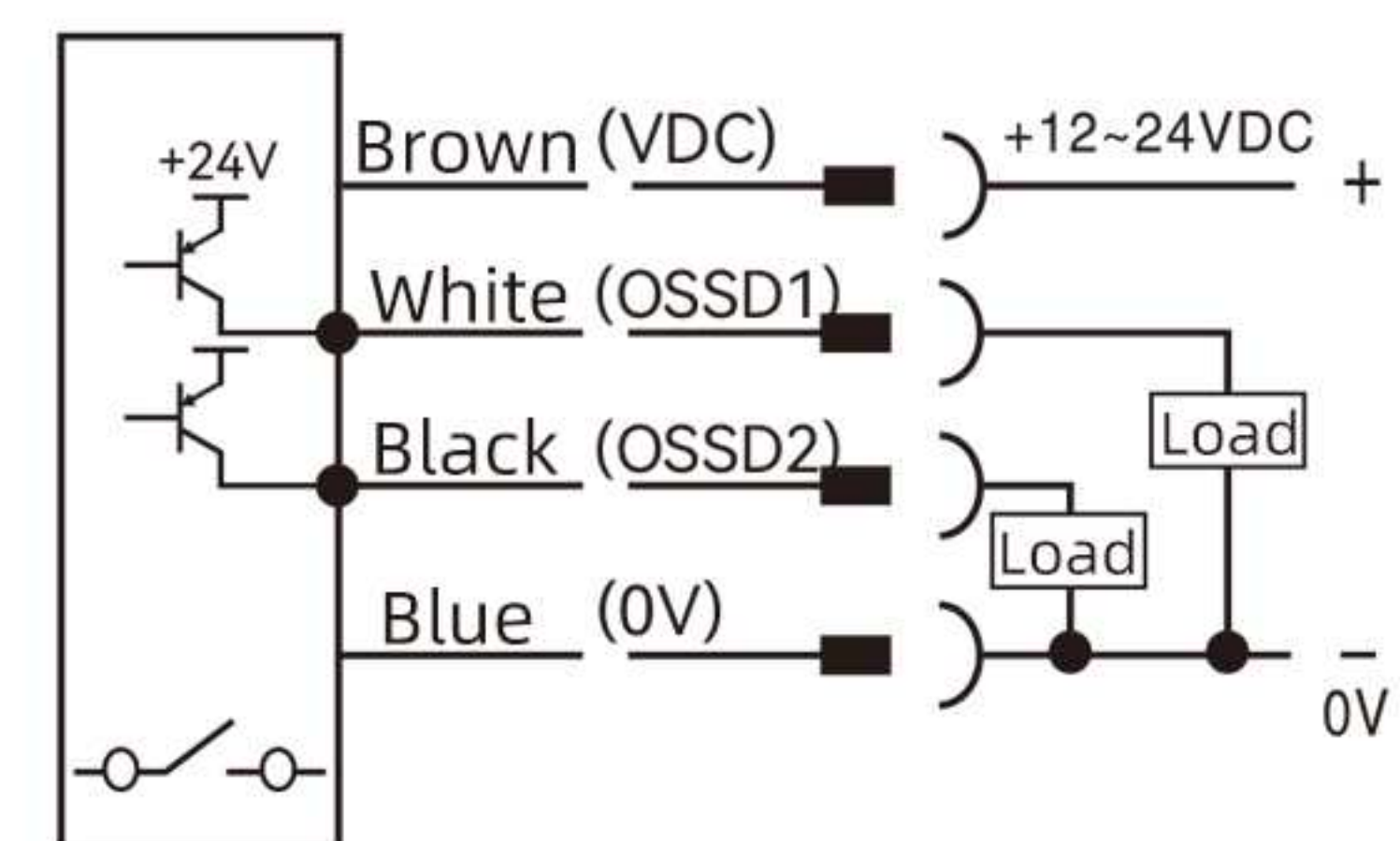

PNP NO

Synchronization

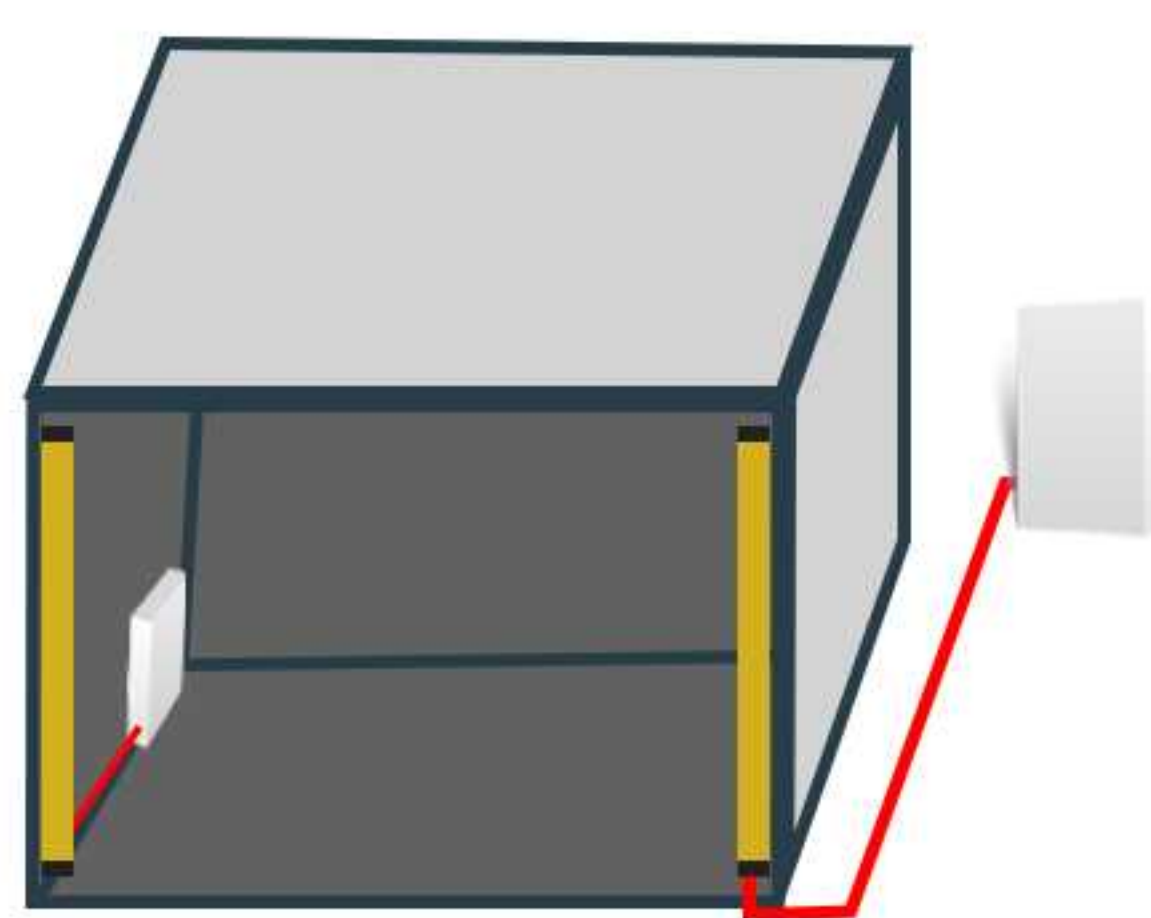

Light Synchronization: No wire connection between the light curtain emitter and receiver (suitable for long firing distances and difficult wiring between emitter and receiver)
Wire Synchronization: A wire is connected between the light curtain transmitter and receiver (for inspection and measurement purposes or where a fast light curtain response is required).

*Our product is light synchronized

Installation



Upper and lower right angle brackets: for two-end mounting (standard)
T-screws: for side-slot mounting (standard)
Convex nut: for side-slotted mounting (optional)
Stainless steel tube bracket: for tubular mounting (optional)

Signal difference between NPN and PNP

Signal output	Light curtain output voltage		Light curtain driving ability		What happens when the encoder signal is received on the device PLC in the on-off condition?	
	Emit light	Shade from light			If light curtain out of power	If light curtain's signal disconnected
NPN NC	0V	24V	0V effective 24V invalid	NPN type Low LEV effective High LEV invalid (Effective means driving ability)	Device stopped	Device stopped
NPN NO	24V	0V	0V effective 24V invalid		Device not stopped	Device not stopped
PNP NC	24V	0V	24V effective 0V invalid	PNP type High LEV effective Low LEV invalid (Effective means driving ability)	Device stopped	Device stopped
PNP NO	0V	24V	24V effective 0V invalid		Device not stopped	Device not stopped

*The signal line connection to the device is disconnected and the device needs to be stopped.

*The light curtain is out of power and the device needs to be stopped.

*Only by selecting a normally closed signal can the device be stopped if the signal is disconnected or if the light curtain is out of power

***As a "safety guard" it is recommended to select a "normally closed" signal and to connect "both signals" to the control system of the machine.**

Methods for adjusting the light curtain

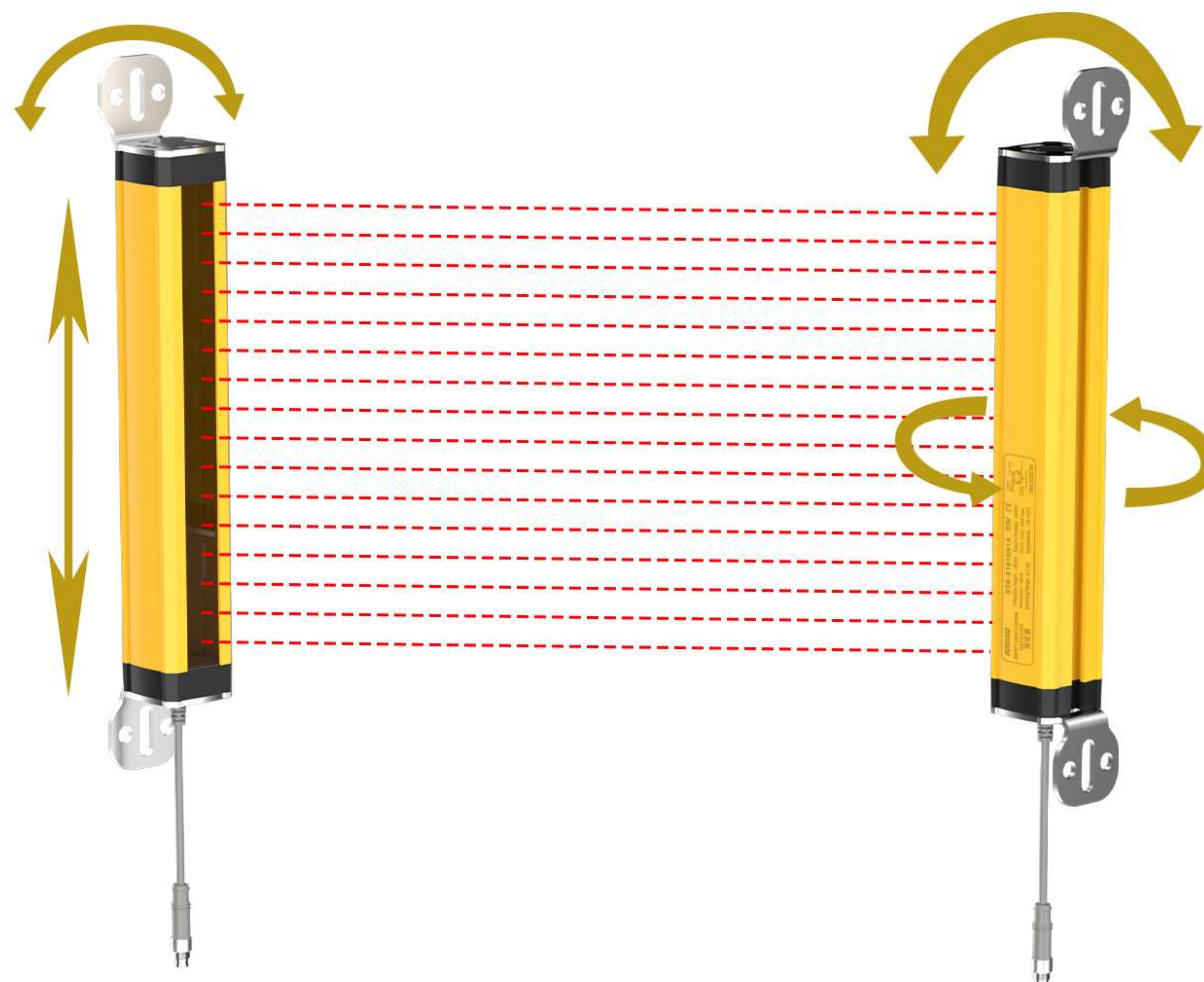

1. Rotate the light curtain Transmitter or receiver body so that the Transmitter and receiver face each other

2. Move the Transmitter or receiver up and down so that the Transmitter is at the same height as the receiver

3. The light curtain Transmitter or receiver forward or backward so that the Transmitter and receiver are flat.

4. The Transmitter and receiver left or right so that the Transmitter and receiver are in the same plane.

Product performance characteristics

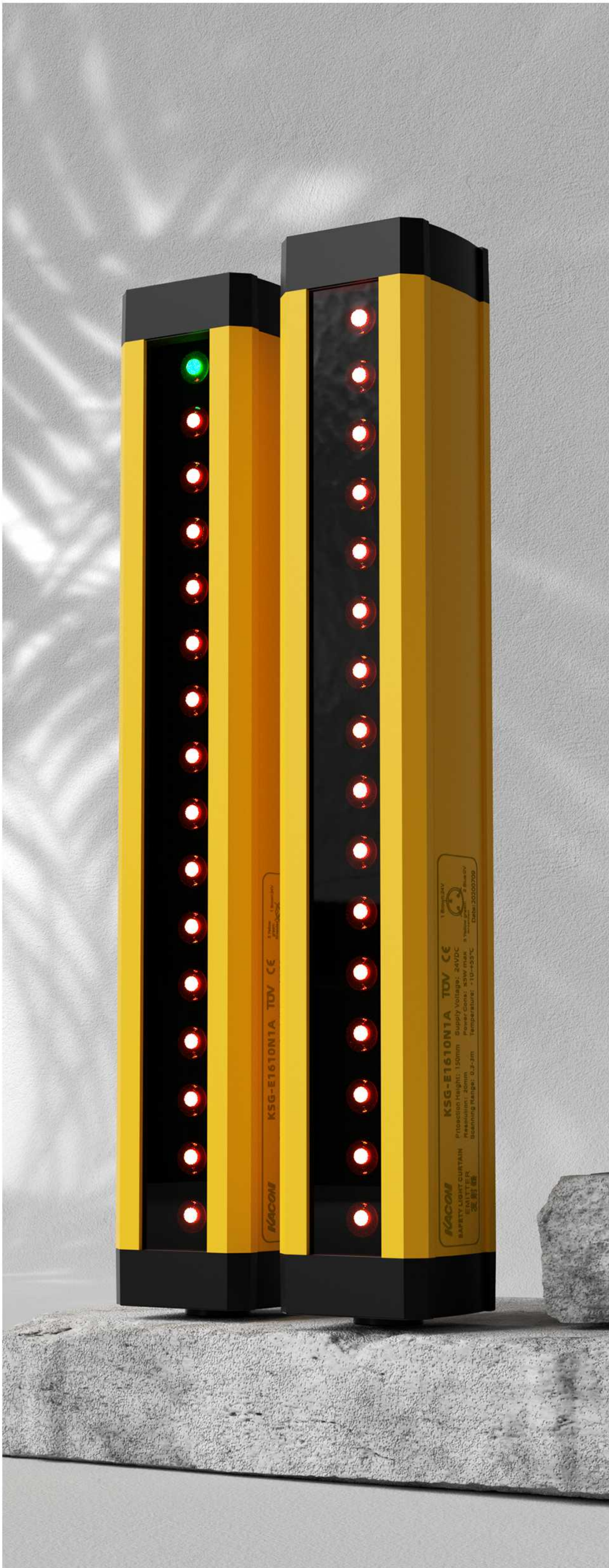

- **Optical synchronization technology**

Light curtains are light-synchronized, eliminating the need for wiring and saving installation time

- **Flexible and convenient settings**

Compact size, beautiful appearance, easy to install and debug, with a high cost performance.

- **Super anti-interference ability**

The system effectively shields against electromagnetic signals, flashing lights, welding arcs and surrounding light sources.

- **Compliance with international standards**

The product complies with IEC61496-1/2 standard safety level, as well as TUV and CE certificates.

- **Response time <15ms**

Ultra-fast response time for your security.

- **High-quality selection of materials, solid materials**

The products are made of high quality and strict materials, and the surface adopts the mounting technology, which is sturdy and durable, with superior anti-vibration performance.

- **Complete accessories**

The product can be linked with the cable (M12) through the aviation socket, the size design 29.3mm * 29.3mm, and all electronic components are used in well-known brands of accessories

Outline dimension diagram

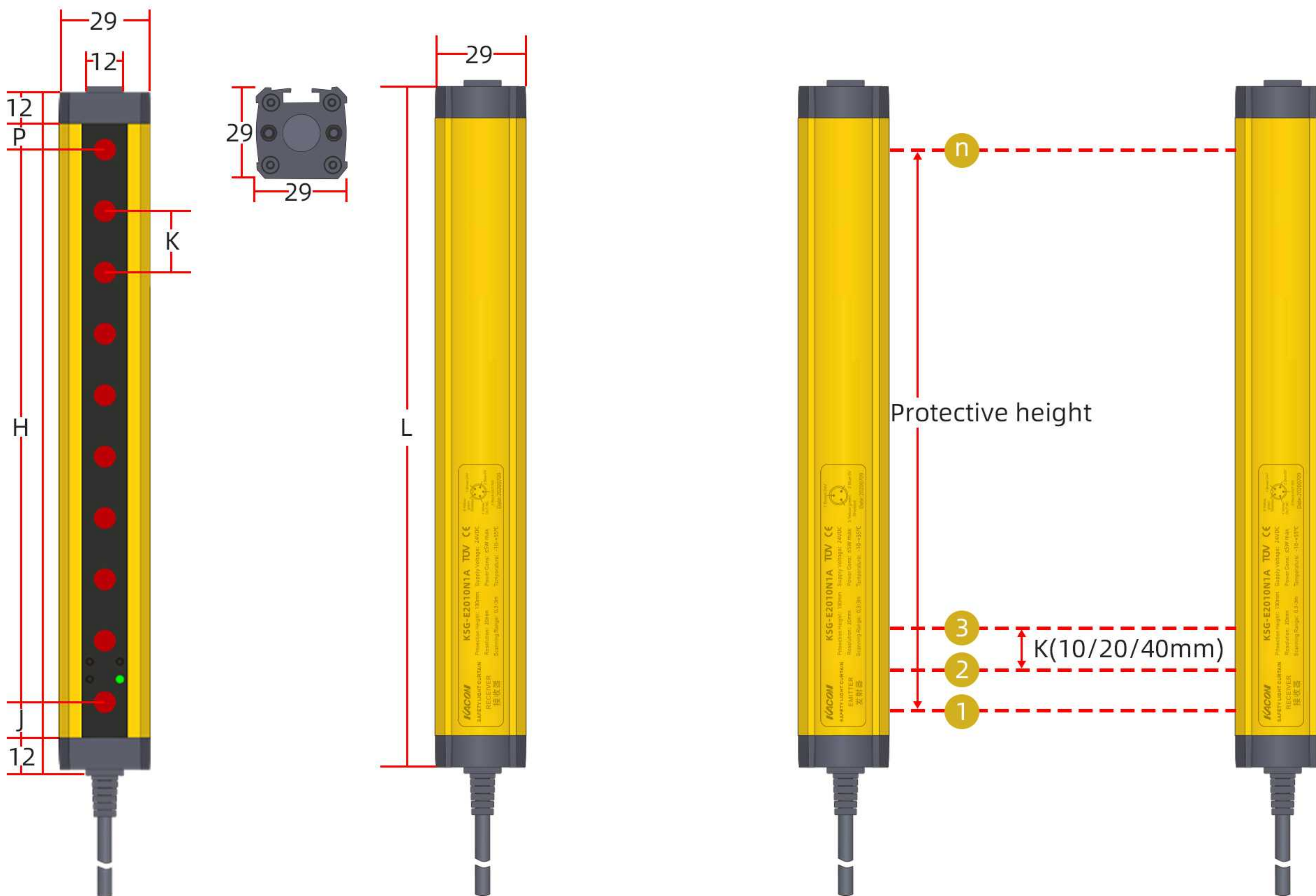

K (mm)	P (mm)	J (mm)
10	5	10
14	5	10
20	10	10
40	10	10

* $H = (n-1) \times K =$ Protective height
 L: Total height of light curtain
 K: Optical axis spacing
 n: Number of optical axes
 $L = P + H + J + 12\text{mm} + 12\text{mm}$

Naming resolution

KSG-E-



Number of optical axes

Optical axis spacing

Outout method

Stand-off distance

Installation

04
06
08
10
...
200

10:10mm
14:14mm
20:20mm
25:20mm
30:30mm
40:40mm

N1:NPN 1NO/1NC
N2:NPN 2NC
N3:NPN 2NO
P1:PNP 1NO/NC
P2:PNP 2NC
P3:PNP 2NO

A:0.3~3m
B:0.3~6m

None: Default L-side mount bracket + T-shape/retaining screws
Y: Steel pipe movable bracket
P: Convex Screw Slot

***Models cannot be combined in any way**

Specification Overview Table

Optical axis spacing 10mm (K)						
Number of beams	Model	Protective height(H)	Light curtain height(L)	Signal output method		Detection distance
				NPN	PNP	
8	KSG-E0810N1A	70	109	N	P	0.3~3m
10	KSG-E1010N1A	90	129	N	P	0.3~3m
12	KSG-E1210N1A	110	149	N	P	0.3~3m
14	KSG-E1410N1A	130	169	N	P	0.3~3m
16	KSG-E1610N1A	150	189	N	P	0.3~3m
18	KSG-E1810N1A	170	209	N	P	0.3~3m
20	KSG-E2010N1A	190	229	N	P	0.3~3m
22	KSG-E2210N1A	210	249	N	P	0.3~3m
24	KSG-E2410N1A	230	269	N	P	0.3~3m
26	KSG-E2610N1A	250	289	N	P	0.3~3m
28	KSG-E2810N1A	270	309	N	P	0.3~3m
30	KSG-E3010N1A	290	329	N	P	0.3~3m
32	KSG-E3210N1A	310	349	N	P	0.3~3m
34	KSG-E3410N1A	330	369	N	P	0.3~3m
36	KSG-E3610N1A	350	389	N	P	0.3~3m
38	KSG-E3810N1A	370	409	N	P	0.3~3m
40	KSG-E4010N1A	390	429	N	P	0.3~3m
42	KSG-E4210N1A	410	449	N	P	0.3~3m
44	KSG-E4410N1A	430	469	N	P	0.3~3m
...	KSG-E...10N1A	N	P	0.3~3m
198	KSG-E19810N1A	1970	2009	N	P	0.3~3m
200	KSG-E20010N1A	1990	2029	N	P	0.3~3m

Optical axis spacing 14mm (K)						
Number of beams	Model	Protective height(H)	Light curtain height(L)	Signal output method		Detection distance
				NPN	PNP	
8	KSG-E0814N1A	98	137	N	P	0.3~3m
10	KSG-E1014N1A	126	165	N	P	0.3~3m
12	KSG-E1214N1A	154	193	N	P	0.3~3m
14	KSG-E1414N1A	182	221	N	P	0.3~3m
16	KSG-E1614N1A	210	249	N	P	0.3~3m
18	KSG-E1814N1A	238	277	N	P	0.3~3m
20	KSG-E2014N1A	266	305	N	P	0.3~3m
22	KSG-E2214N1A	294	333	N	P	0.3~3m
24	KSG-E2414N1A	322	361	N	P	0.3~3m
26	KSG-E2614N1A	350	389	N	P	0.3~3m
28	KSG-E2814N1A	378	417	N	P	0.3~3m
30	KSG-E3014N1A	406	445	N	P	0.3~3m
32	KSG-E3214N1A	434	473	N	P	0.3~3m
34	KSG-E3414N1A	462	501	N	P	0.3~3m
36	KSG-E3614N1A	490	529	N	P	0.3~3m
38	KSG-E3814N1A	518	557	N	P	0.3~3m
40	KSG-E4014N1A	546	585	N	P	0.3~3m
42	KSG-E4214N1A	574	613	N	P	0.3~3m
44	KSG-E4414N1A	602	641	N	P	0.3~3m
...	KSG-E...14N1A	N	P	0.3~3m
198	KSG-E19814N1A	2758	2797	N	P	0.3~3m
200	KSG-E20014N1A	2786	2825	N	P	0.3~3m

Optical axis spacing 20mm (K)						
Number of beams	Model	Protective height(H)	Light curtain height(L)	Signal output method		Detection distance
				NPN	PNP	
6	KSG-E0620N1A	100	144	N	P	0.3~3m
8	KSG-E0820N1A	140	184	N	P	0.3~3m
10	KSG-E1020N1A	180	224	N	P	0.3~3m
12	KSG-E1220N1A	220	264	N	P	0.3~3m
14	KSG-E1420N1A	260	304	N	P	0.3~3m
16	KSG-E1620N1A	300	344	N	P	0.3~3m
18	KSG-E1820N1A	340	384	N	P	0.3~3m
20	KSG-E2020N1A	380	424	N	P	0.3~3m
22	KSG-E2220N1A	420	464	N	P	0.3~3m
24	KSG-E2420N1A	460	504	N	P	0.3~3m
26	KSG-E2620N1A	500	544	N	P	0.3~3m
28	KSG-E2820N1A	540	584	N	P	0.3~3m
30	KSG-E3020N1A	580	624	N	P	0.3~3m
32	KSG-E3220N1A	620	664	N	P	0.3~3m
34	KSG-E3420N1A	660	704	N	P	0.3~3m
36	KSG-E3620N1A	700	744	N	P	0.3~3m
38	KSG-E3820N1A	740	784	N	P	0.3~3m
40	KSG-E4020N1A	780	824	N	P	0.3~3m
42	KSG-E4220N1A	820	864	N	P	0.3~3m
...	KSG-E...20N1A	N	P	0.3~3m
198	KSG-E19820N1A	3940	3984	N	P	0.3~3m
200	KSG-E20020N1A	3980	4024	N	P	0.3~3m

Optical axis spacing 40mm (K)						
Number of beams	Model	Protective height(H)	Light curtain height(L)	Signal output method		Detection distance
				NPN	PNP	
4	KSG-E0440N1A	120	164	N	P	0.3~3m
6	KSG-E0640N1A	200	244	N	P	0.3~3m
8	KSG-E0840N1A	280	324	N	P	0.3~3m
10	KSG-E1040N1A	360	404	N	P	0.3~3m
12	KSG-E1240N1A	440	484	N	P	0.3~3m
14	KSG-E1440N1A	520	564	N	P	0.3~3m
16	KSG-E1640N1A	600	644	N	P	0.3~3m
18	KSG-E1840N1A	680	724	N	P	0.3~3m
20	KSG-E2040N1A	760	804	N	P	0.3~3m
22	KSG-E2240N1A	840	884	N	P	0.3~3m
24	KSG-E2440N1A	920	964	N	P	0.3~3m
26	KSG-E2640N1A	1000	1044	N	P	0.3~3m
28	KSG-E2840N1A	1080	1124	N	P	0.3~3m
30	KSG-E3040N1A	1160	1204	N	P	0.3~3m
32	KSG-E3240N1A	1240	1284	N	P	0.3~3m
34	KSG-E3440N1A	1320	1364	N	P	0.3~3m
36	KSG-E3640N1A	1400	1444	N	P	0.3~3m
38	KSG-E3840N1A	1480	1524	N	P	0.3~3m
40	KSG-E4040N1A	1560	1604	N	P	0.3~3m
...	KSG-E...40N1A	N	P	0.3~3m
198	KSG-E19840N1A	7880	7924	N	P	0.3~3m
200	KSG-E20040N1A	7960	8004	N	P	0.3~3m

***Output mode see specifications. Special specifications can be additionally customized, up to 200 beams; detection distance default 0.3 ~ 3m, beyond the default distance, please contact customer service!**

Product technical parameters

Light curtain form	Directional			
Optical axis spacing	10mm	14mm	20mm	40mm
Detection accuracy	18mm	22mm	28mm	48mm
Number of beams	8、10 … 200	6、8 … 200	6、8 … 200	4、6 … 200
Protective height	Optical axis spacing x (numbers of optical axis - 1)			
Detection distance	30~3000mm、30~6000mm			
Response time	≤15ms			
Optical anti-interference	10000Lux(Angle of incidence≥5°)			
Size	29.3mm × 29.3mm × L(L: length of transmitter / receiver)			
IP rating	IP65			
Controller	KCA KCA2			
Power supply voltage	DC12/24V AC110~220V(Relay output)			
Current consumption	≤200mA			
Output	NPN/PNP type, filling current 500mA, voltage below 1.5V, polarity, short circuit, overload protection			
Output state	ON (Receiver indicator green)			
Indicator	Transmitter: power indicator (Red); Receiver: output indicator (Green), shade (Red)			
Light source	Modulated infrared LEDs			
Connection method	Round aviation socket, with dedicated connection cable, 3 cores transmitter, 5 cores receiver			
Housing material	Aluminum alloy, cover: ABS reinforced nylon			
Ambient light resistance	Incandescent light: Illumination of the lighted surface 3000LX; Sunlight: Illumination of the lighted surface 10000LX			
Ambient temperature	Working: -10°C~+40°C (no frozen), storing: -25°C~+55°C			
Ambient humidity	Working: 35~85%RH, storing: 35~95%RH			

Wiring diagram

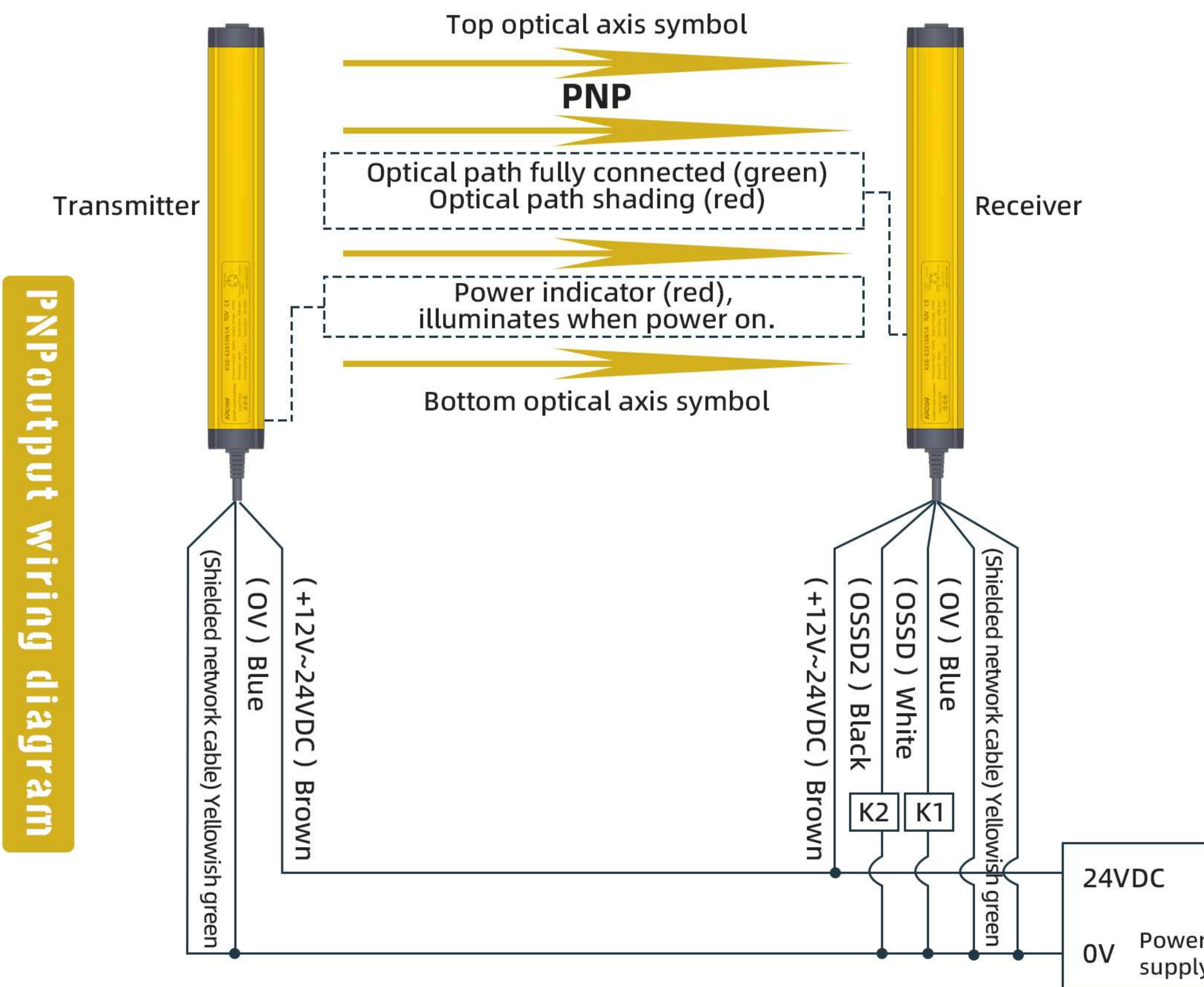
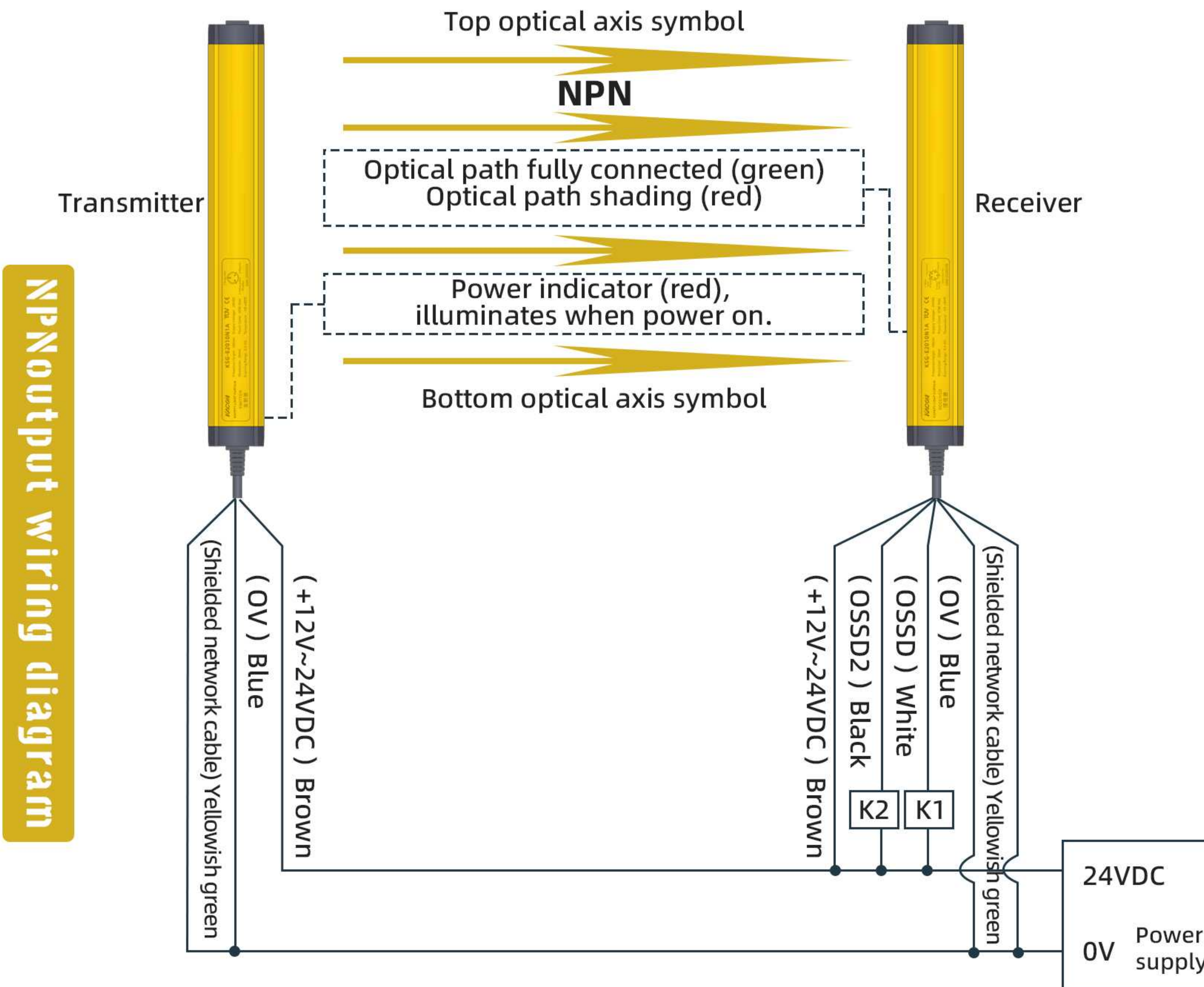

Accessory Selection Guide

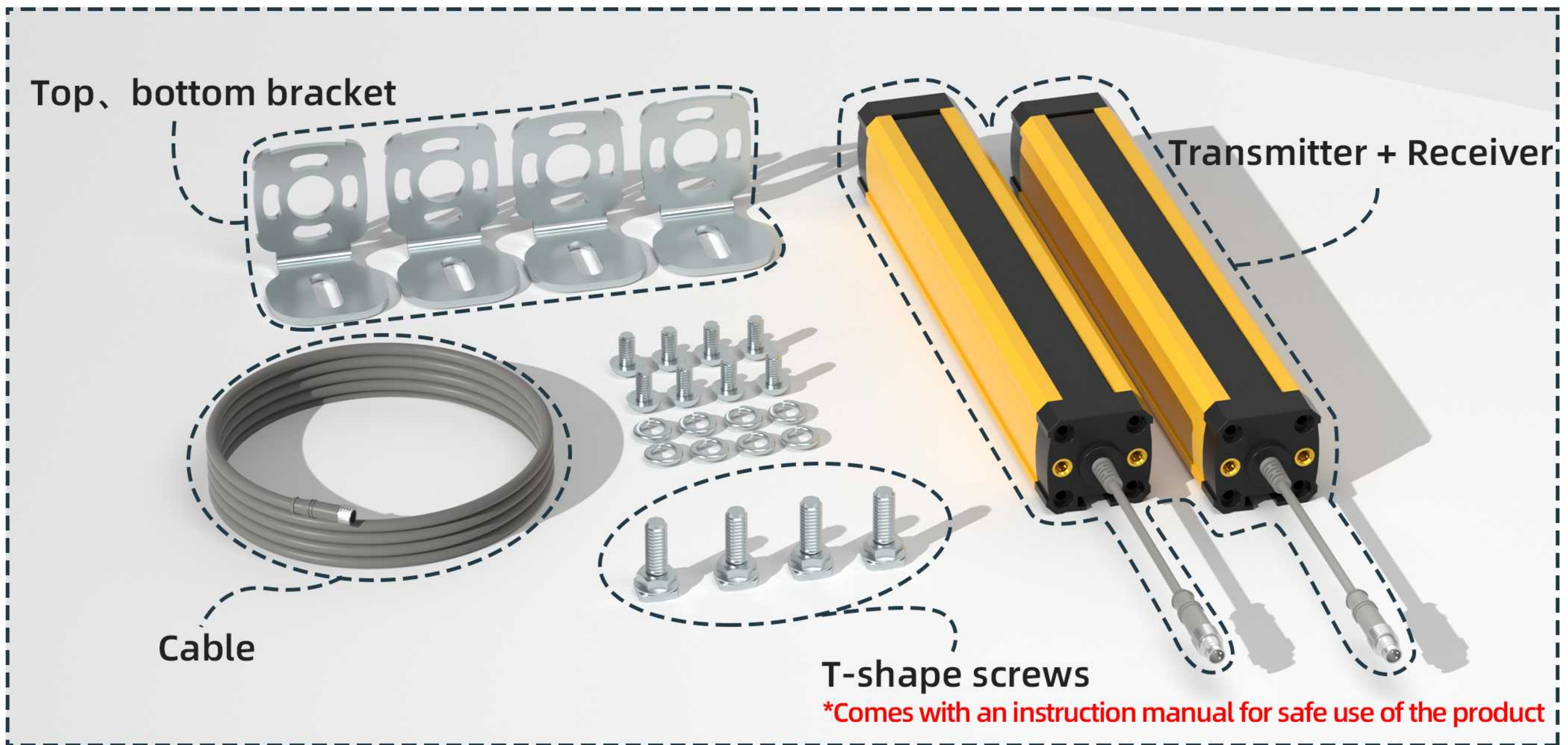

Name	Shape	Size (Unit: mm)	Application
T-shape screws			
Top, bottom bracket			
Convex nuts			
Stainless steel brackets			