

Solid State Relay Current Monitor

KSR CMD

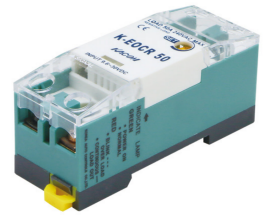

KSR Current Monitoring Detector

- Short circuit and overload monitoring
- Overload level control
- NPN open collector output
- Two-color chip wide window
 - Red: Overheating alarm
 - Green: Normal operation
- Din-rail or surface-mounted
- Combined use of KSR & KSC

General Specification

▶ Input Ratings (Ambient Temperature 25°C)		▶ Load Ratings		▶ Alarm Ratings	
Rated Control Voltage	12 - 24VDC	Rated Load Voltage	100 - 240VAC (50 / 60 Hz)	Off-State Collector Dielectric Voltage	Maximum 30VDC
Control Voltage Range	9.6 - 30VDC	Maximum Switching Current	50A	Maximum Switching Current	0.1A
Input Current	15mA	Minimum Switching Current	3A	Output Type	NPN Open Collector
▶ General Ratings					
Insulation Resistance	100MΩ DC 500V				
Dielectric Strength	2,500VAC, 50/60Hz				
Vibration Resistance	10 - 55 - 10Hz Side Vibration 0.35mm (Both Vibration 0.7mm)				
Shock Resistance	294m/s ²				
Storage Temperature	-30 - 70°C (with no icing or condensing)				
Ambient Temperature	-20 - 60°C (with no icing or condensing)				
Ambient Humidity	45 - 85%RH (no condensing)				

	Load	Input
Terminal	3.5 - 4.0	2.0 - 3.5
Screw	M4.0	M3.5
Torque Max / N-m	1.2	0.8

Dimension

unit : mm

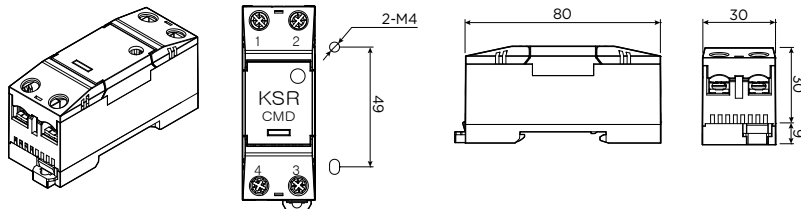

	Load	Input
터미널	3.5 - 4.0	2.0 - 3.5
나사	M4.0	M3.5
Torque Max / N-m	1.2	0.8

- NPN Open Output Collector & Overload Level Control

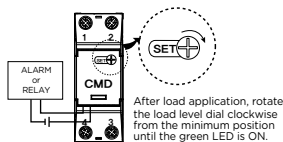

- Wiring

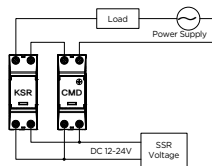

- Wiring Diagram

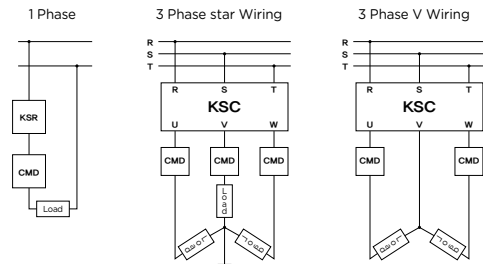

- ▶ Monitoring Function
 - Normal operation: Green lamp on
 - Short circuit: Red lamp on / NPN Open Collector output
 - Overload: Red lamp flashing / NPN Open Collector output

- ▶ Caution

- Use the same power supply for KSR / KSC and CMD input. Otherwise, the short circuit monitoring function does not work.
- The input voltage must be within the range of rating, without fluctuation. Otherwise, the monitoring level (load current value) set by the user may change and operating errors may occur.
- The alarm output is NPN Open Collector output. Use the product at 0.1A/30VDC or less.

Solid State Relay Current Monitor

KSR & KSC Series

Heatsink

KHS 015 - □

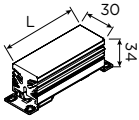

□ : 080 / 100 / 120

KHS 030 - □

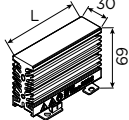

□ : 080 / 100 / 120

KHS 045 - □

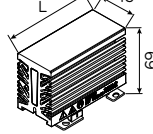

□ : 080 / 100 / 120

KHS 080 - □

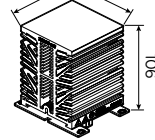

□ : 080 / 100 / 120

KHS 120 - □

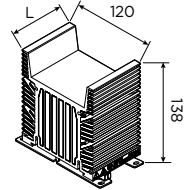

□ : 080 / 100 / 120 / 130

- Maximized heat-radiating surface area via innovative design
- Exclusive advanced Al alloy material for heat radiation
- Special thermal processing for high efficiency use
- Anti-corrosion anodizing surface treatment
- Easily removable structure of air blow fan

- Provision of multiple extended types
 - Optimal heat radiator selectable
 - For diverse environment

- In-house production
 - Stable quality and supply
 - Quick response to special products

Fan

unit : mm

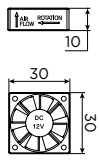

12 VDC

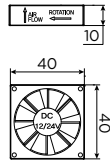

12 / 24 VDC

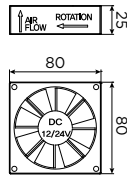

12 / 24VDC (PA6)
100 / 220VAC 50 - 60Hz (AL alloy)

Easily removable structure

- High-performance ball-bearing type
 - Low noise
 - Prolonged life
- Doubled device life

Technical Data

Input Current & Input Impedance

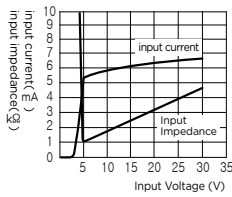

Heatsink Type & Heatsink + Fan Type

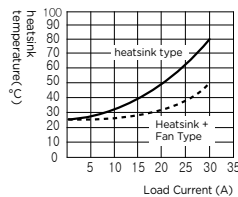

⇒ (ambient temperature 25°C)
vertical mounting

Ambient Temperature-Load Current

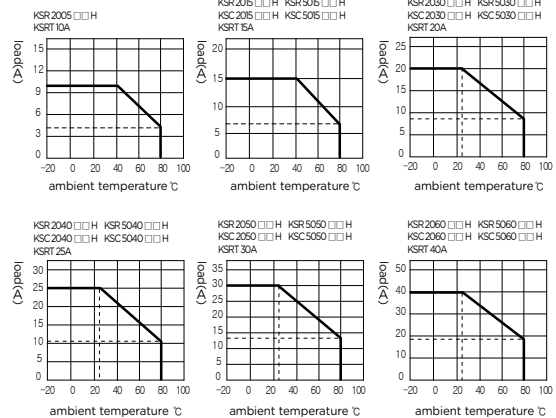

Caution

- The radiator fan reduces the radiator temperature by up to 35 - 40 % (ambient temperature of 25°C / vertical mounting)
- In the design process, note that the load current characteristic worsens with the increase in the ambient temperature.
- With the high-voltage type, design the system at 80 % of the rating or less.
- The device life is prolonged when the temperature decreases.

Solid State Relay Current Monitor

KSR & KSC Series

KSR & KSC Series

Heatsink Type

Vertical Mounting

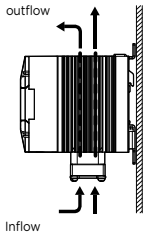

Horizontal Mounting

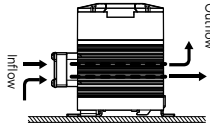

Panel Mounting

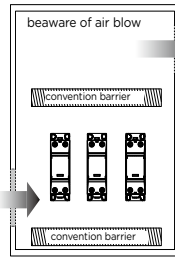

- Direct the fan in the lower direction for vertical installation, and in the air inlet direction for horizontal direction.
- If the horizontally mounted device does not have an integrated fan, use it at 50% of the rated current or less.
- Pay attention to the increase in the ambient temperature from the heating of the device. Especially when mounting the device in the panel, be sure to install a fan for sufficient ventilation.
- Remove any obstacles for air flow around the air inlet and outlet.

General Type

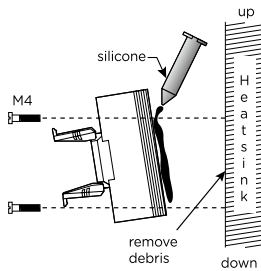

※ silicone grease to provide.

- Be sure to attach the normal KSR/KSC to the heatsink with a high heat radiation performance.
- Do not attach them to low-thermal-conductivity materials, including glass, wood and plastic.
 - Otherwise, it may cause damage to the device and fire.
- Remove the foreign matters from the mounting surface of the radiator or heatsink, and apply silicon grease for heat radiation to the surface.
- The heat radiation effect greatly depends on the mounting condition and silicon grease application. Poor treatment may cause damage to the device.
- The heat radiation effect is ensured when the device and radiator are vertically mounted with good ventilation.
- Tighten the fixing bolts at the specified torque for fixing the device to the radiator.

⇒ KSR, KSC fixing bolt M4-tightening torque 1.2 N·m

KSR Mounting Distance

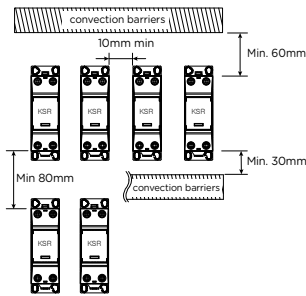

KSC Mounting Distance

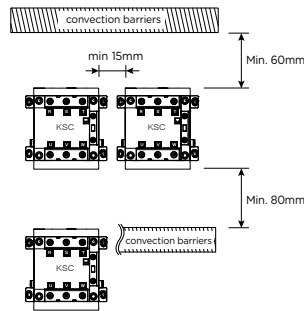

- The heat radiation effect decreases when there is not much room. Limit the load current below the rating.
- Install the device as far as possible from a heating unit, if there is any.
- Allow the longest distance possible between the device and other unit.

EMC Wiring

KSR Type

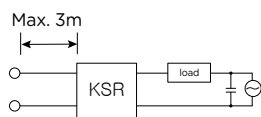

- Connect the film condenser at the Power in Parallel
- Limit the input wire length Maximum 3 m

KSC Type

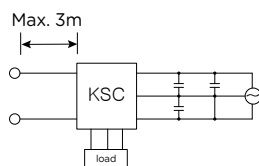

손실시간

- Time Loss
Note that low voltage and current of the load increases time loss. Check if any problem exists.

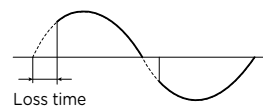

Terminal

- When using crimp terminals, refer to the terminal specifications for terminal part spaces.

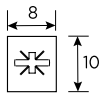
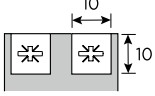
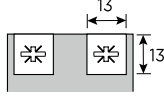
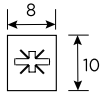
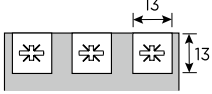
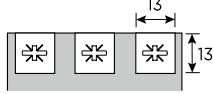
KSR Input Terminal	KSR Load Terminal	
	5 / 15 / 30A Type	40 / 50 / 60 / 80A Type
		
M3.5	M4	M6
KSC Input Terminal	KSC Load Terminal	
	5 / 15 / 30A Type	40 / 50 / 60 / 80A Type
		
M3.5	M4	M6

Rated Terminal specification

unit : mm

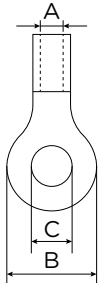

Model	Bolt	A (mm)	B (mm)	C (mm)	Terminal	Wire Ø	Torque Max N·m	
Load	KSR 5 / 15 / 30A	M4.0	3.0	8.3	4.3	3.5-4.0	2.0	1.2
	KSR 40 / 50 / 60A	M6.0	5.8	12.0	6.4	4.0-6.0	4.2	2.5
	KSR 80A	M6.0	5.8	12.0	6.4	4.0-6.0	5.3	2.5
	KSC 15 / 30A	M4.0	3.0	8.3	4.3	3.5-4.0	2.0	1.2
	KSC 40 / 50 / 60A	M6.0	5.8	12.0	6.4	4.0-6.0	4.2	2.5
	KSC 80A	M6.0	5.8	12.0	6.4	4.0-6.0	5.3	2.5
Input	all	M3.5	2.3	6.6	3.7	2.0-3.5	2.0	0.8

☞ input terminal Color : ⊕ red, ⊖ black

- Be sure to conduct wiring only after switching off the power.
- Select the wire size according to the current.
- Tighten screws firmly at the specified torques.
- Applying an excessive torque may cause the screw to fail. Pay attention especially when using an electric driver.
- The screw at the output terminal must not be loosened. Abnormal heating at the terminal may cause fire.
- After wiring, be sure to lock the terminal safety cover in the closed position to prevent an electric shock or a short circuit.